

The information in this prospectus supplement and accompanying prospectus is not complete and may be changed. A registration statement relating to these securities has been declared effective by the Securities and Exchange Commission. This preliminary prospectus supplement and the accompanying prospectus is not an offer to sell these securities and is not soliciting an offer to buy these securities in any jurisdiction where the offer or sale is not permitted.

Filed Pursuant to Rule 424(B)(2)
 Registration No. 333-132750
Issued May 2, 2007

PRELIMINARY PROSPECTUS SUPPLEMENT (Subject to Completion)
 (To prospectus dated March 27, 2006)



\$ % Notes due 2056

We will pay interest on the notes on May 15, August 15, November 15 and February 15 of each year, beginning on August 15, 2007. The notes will bear interest at a rate of % per year and will mature on May 15, 2056. We may redeem the notes, in whole or in part, at any time on or after May 15, 2012 at a redemption price equal to 100% of the principal amount redeemed plus accrued and unpaid interest to the redemption date.

The notes will be unsecured and will rank equally with all of our unsecured and unsubordinated indebtedness. The notes will be fully and unconditionally guaranteed by our wholly-owned cable subsidiaries named in this prospectus supplement and in the accompanying prospectus. The notes will be issued in minimum denominations of \$25 and in multiples of \$25.

We intend to apply to list the notes on the New York Stock Exchange under the symbol “CCS” and, if approved, we expect trading in the notes on the New York Stock Exchange to begin within 30 days after the original issue date. The notes are expected to trade “flat.” This means that purchasers will not pay, and sellers will not receive, any accrued and unpaid interest on the notes that is not included in the trading price.

Investing in the notes involves risks that are described in the “Risk Factors” section of our Annual Report on Form 10-K for the year ended December 31, 2006 and beginning on page S-3 of this prospectus supplement.

	<u>Price to Investors(1)</u>	<u>Underwriters’ Discount(2)</u>	<u>Proceeds to Us Before Expenses</u>
Per note	%	%	%
Total	\$	\$	\$

(1) Plus accrued interest, if any, from May , 2007, if settlement occurs after that date.

(2) Represents the weighted average underwriting discount for orders by retail and institutional investors. See “Underwriting” beginning on page S-13 of this prospectus supplement for a discussion regarding underwriting discounts.

Neither the Securities and Exchange Commission nor any state securities commission has approved or disapproved of these securities or determined if this prospectus supplement or the accompanying prospectus is truthful or complete. Any representation to the contrary is a criminal offense.

We have granted the underwriters the right to purchase up to an additional \$ aggregate principal amount of notes to cover over-allotments.

The notes will be ready for delivery only through The Depository Trust Company and its participants, including Euroclear and Clearstream, in book-entry form on or about May , 2007.

Joint Book-Running Managers

Citi

Morgan Stanley

A.G. Edwards

Merrill Lynch & Co.

UBS Investment Bank

Wachovia Securities

RBC Capital Markets

**Banc of America Securities LLC
 JPMorgan**

**Deutsche Bank Securities
 Lehman Brothers**

The date of this prospectus supplement is May , 2007.

TABLE OF CONTENTS
Prospectus Supplement

	<u>Page</u>
Prospectus Supplement Summary	S-1
Risk Factors	S-3
Selected Historical Consolidated Financial Data	S-5
Use of Proceeds	S-6
Ratio of Earnings to Fixed Charges	S-6
Description of the Notes	S-7
Material U.S. Federal Income Tax Consequences For Non-U.S. Holders	S-11
Underwriting	S-13
Legal Matters	S-17

Prospectus

The Companies	1
Caution Concerning Forward-Looking Statements	3
Use of Proceeds	3
Dividend Policy	3
Ratios of Earnings to Fixed Charges	3
Ratio of Earnings to Combined Fixed Charges and Preferred Dividends	4
Description of Debt Securities and Cable Guarantees	5
Global Securities	18
Description of Capital Stock	20
Plan of Distribution	24
Legal Matters	25
Experts	25
Available Information	25
Incorporation of Certain Documents by Reference	26

You should rely only on the information contained or incorporated by reference in this prospectus supplement, the accompanying prospectus and the free writing prospectus relating to the notes. We have not, and the underwriters have not, authorized any other person to provide you with different information. If anyone provides you with different or inconsistent information, you should not rely on it. We are not, and the underwriters are not, making an offer to sell these securities in any jurisdiction where the offer or sale is not permitted. You should assume that the information appearing in this prospectus supplement, the accompanying prospectus and the documents incorporated by reference is accurate only as of their respective dates. Our business, financial condition, results of operations and prospects may have changed since those dates.

(This page has been left blank intentionally.)

PROSPECTUS SUPPLEMENT SUMMARY

The Companies

Comcast Corporation

We are the largest cable operator in the United States and offer a variety of consumer entertainment and communication products and services. As of March 31, 2007, our cable systems served approximately 24.2 million video subscribers, 12.1 million high-speed Internet subscribers and 3.0 million phone subscribers.

We classify our operations in two reportable segments: “Cable” and “Programming”.

Our Cable segment develops, manages and operates our cable systems, including video, high-speed Internet and phone services (“cable services”). The majority of our Cable segment revenue is earned from monthly subscriptions for these cable services. Other revenue sources include advertising and the operation of our regional sports and news networks. The Cable segment generates approximately 95% of our consolidated revenues.

Our Programming segment consists of our six national programming networks: E!, Style, The Golf Channel, VERSUS (formerly known as OLN), G4, and AZN Television; and other entertainment-related businesses. Revenue from our Programming segment is earned primarily from advertising revenues and from monthly per subscriber license fees paid by cable and satellite distributors.

For a description of our business, financial condition, results of operations and other important information regarding us, see our filings with the SEC incorporated by reference in the accompanying prospectus. For instructions on how to find copies of these and our other filings incorporated by reference in the accompanying prospectus, see “Available Information” in the accompanying prospectus.

Our principal executive office is located at 1500 Market Street, Philadelphia, Pennsylvania 19102-2148. Our telephone number is (215) 665-1700. The address of our web site is www.comcast.com. The information on our web site is not part of this prospectus supplement or the accompanying prospectus.

Cable Guarantors

Our obligations, including the payment of principal, premium, if any, and interest on the notes will be fully and unconditionally guaranteed by each of Comcast Cable Communications, LLC, Comcast Cable Communications Holdings, Inc., Comcast Cable Holdings, LLC, Comcast MO Group, Inc. and Comcast MO of Delaware, LLC. In this prospectus supplement, we refer to these guarantors as the cable guarantors and to these guarantees as the cable guarantees.

The cable guarantees will not contain any restrictions on the ability of any cable guarantor to:

- pay dividends or distributions on, or redeem, purchase, acquire, or make a liquidation payment with respect to, any of that cable guarantor’s capital stock; or
- make any payment of principal, interest or premium, if any, on or repay, repurchase or redeem any debt securities of that cable guarantor.

Each cable guarantor’s principal place of business is 1500 Market Street, Philadelphia, Pennsylvania 19102-2148.

The Offering

Issuer	Comcast Corporation.
Securities Offered	\$ (\$ if the underwriters exercise their overallotment option in full) aggregate principal amount of % Notes due 2056.
Maturity	The notes will mature on May 15, 2056.
Interest	Interest on the notes will accrue at the rate of % per year, payable quarterly in cash in arrears on each May 15, August 15, November 15 and February 15, beginning on August 15, 2007.
Ranking	The notes will be unsecured and will rank equally with all of our unsecured and unsubordinated indebtedness.
Cable Guarantors	Comcast Cable Communications, LLC, Comcast Cable Communications Holdings, Inc., Comcast Cable Holdings, LLC, Comcast MO Group, Inc. and Comcast MO of Delaware, LLC.
Cable Guarantees	The cable guarantors will fully and unconditionally guarantee the notes, including the payment of principal, premium, if any, and interest. The cable guarantees will rank equally with all other general unsecured and unsubordinated obligations of the cable guarantors.
Optional Redemption	We may redeem the notes, in whole or in part, at any time on or after May 15, 2012 at a redemption price equal to 100% of the principal amount redeemed plus accrued and unpaid interest to the redemption date.
Use of Proceeds	We intend to use the proceeds from this offering, after deducting fees and expenses related to this offering, for working capital and general corporate purposes, which may include funding repayment of commercial paper issued to repay, in part, \$600 million aggregate principal amount of our 8.375% notes due May 1, 2007. Our commercial paper has a weighted average interest rate of 5.358% and an average maturity of 10 days.

Book Entry

The notes will be issued in book-entry form and will be represented by global notes deposited with, or ~~for~~ on behalf of, DTC and registered in the name of DTC or its nominees. Beneficial interests in any of the notes will be shown on, and transfers will be effected only through, records maintained by DTC or its nominee, and these beneficial interests may not be exchanged for certificated notes, except in limited circumstances. See “Description of the Notes — Book-Entry System” in this prospectus supplement.

RISK FACTORS

Prospective investors should carefully consider all of the information set forth in this prospectus supplement, the accompanying prospectus and any documents incorporated herein by reference before deciding to invest in any of the notes. The following is not intended as, and should not be construed as, an exhaustive list of relevant risk factors. There may be other risks that a prospective investor should consider that are relevant to its own particular circumstances or generally.

We and our subsidiaries have significant debt and debt-like obligations and may not maintain investment-grade credit ratings.

We and our subsidiaries have a significant amount of debt and debt-like obligations. Our credit rating and the credit ratings of our subsidiaries may in the future be lower than the current or historical credit ratings. In addition, it is possible that we or any of our subsidiaries that issue debt may not obtain or maintain an investment-grade credit rating. Differences in credit ratings would affect the interest rates charged on financings, as well as the amounts of indebtedness, types of financing structures and debt markets that may be available to us and our subsidiaries. A downgrade in our or any of our subsidiaries' existing credit ratings or failure by us and our subsidiaries to maintain investment-grade credit ratings could have a material adverse effect on our operating results, our ability to obtain additional financing and on the market value of the notes.

The indenture that governs the notes does not restrict our ability to incur additional indebtedness, which could make our debt securities more risky in the future.

As of March 31, 2007, our consolidated indebtedness was approximately \$28.3 billion. The indenture that governs the notes does not restrict our ability or our subsidiaries' ability to incur additional indebtedness. The degree to which we incur additional debt could have important consequences to holders of the notes, including:

- limiting our ability to obtain any necessary financing in the future for working capital, capital expenditures, debt service requirements or other purposes;
- requiring us to dedicate a substantial portion of our cash flows from operations to the payment of indebtedness and not for other purposes, such as working capital and capital expenditures;
- limiting our flexibility to plan for, or react to, changes in our businesses;
- making us more indebted than some of our competitors, which may place us at a competitive disadvantage; and
- making us more vulnerable to a downturn in our businesses.

Although we intend to apply to list the notes on the New York Stock Exchange, we cannot assure you that an active trading market will develop for the notes.

The notes are a new issue of securities for which there is no trading market. Although we intend to apply to list the notes on the New York Stock Exchange, we can provide no assurance regarding the future development or maintenance of a market for the notes or the ability of holders of the notes to sell their notes. If such a market were to develop on the New York Stock Exchange or otherwise, the notes could trade at prices which may be higher or lower than the initial offering price depending on many factors independent of our creditworthiness, including, among other things:

- the time remaining to the maturity of the notes;

Table of Contents

- the outstanding principal amount of the notes; and
- the level, direction and volatility of market interest rates generally.

We may choose to redeem the notes prior to maturity.

We may redeem all or a portion of the notes at any time on or after May 15, 2012 at a redemption price equal to 100% of the principal amount redeemed plus accrued and unpaid interest to the redemption date. If prevailing interest rates are lower at the time of redemption, you may not be able to reinvest the redemption proceeds in a comparable security at an interest rate as high as the interest rate of the notes being redeemed. Our redemption right may also adversely affect your ability to sell your notes as May 15, 2012 approaches and after such date.

SELECTED HISTORICAL CONSOLIDATED FINANCIAL DATA

The following table sets forth our selected consolidated financial data. The selected consolidated financial data as of and for each of the years in the five-year period ended December 31, 2006 were derived from our audited consolidated financial statements. You should read the following data in conjunction with our consolidated financial statements and notes and Management's Discussion and Analysis of Financial Condition and Results of Operations included in our Annual Report on Form 10-K for the year ended December 31, 2006 and our Quarterly Report on Form 10-Q for the quarter ended March 31, 2007, each of which are incorporated herein by reference.

	Year Ended December 31					Three Months Ended March 31	
	2002	2003	2004	2005	2006	2006	2007
	(In millions, except per share data)						
Statement of Operations Data:							
Revenues	\$7,997	\$17,330	\$19,221	\$21,075	24,966	\$ 5,595	\$ 7,388
Operating income	948	1,938	2,829	3,521	4,619	1,004	1,261
Income (loss) from continuing operations	(452)	(222)	928	828	2,235	438	837
Discontinued operations(1)(2)	178	3,462	42	100	298	28	—
Net income (loss)	(274)	3,240	970	928	2,533	466	837
Basic earnings (loss) for common stockholders per common share(3)							
Income (loss) from continuing operations	\$ (0.27)	\$ (0.07)	\$ 0.28	\$ 0.25	0.71	\$ 0.14	\$ 0.27
Discontinued operations(1)(2)	0.11	1.02	0.01	0.03	0.09	0.01	—
Net income (loss)	\$ (0.16)	\$ 0.95	\$ 0.29	\$ 0.28	0.80	\$ 0.15	\$ 0.27
Diluted earnings (loss) for common stockholders per common share(3)							
Income (loss) from continuing operations	\$ (0.27)	\$ (0.07)	\$ 0.28	\$ 0.25	0.70	\$ 0.14	\$ 0.26
Discontinued operations(1)(2)	0.11	1.02	0.01	0.03	0.09	0.01	—
Net income (loss)	\$ (0.16)	\$ 0.95	\$ 0.29	\$ 0.28	0.79	\$ 0.15	\$ 0.26

(1) In September 2003, we disposed of our interest in QVC to Liberty Media Corporation. QVC is presented as a discontinued operation for the years ended on and before December 31, 2003.

(2) In July 2006, in connection with the transactions with Adelphia and Time Warner, we transferred our previously owned cable systems located in Los Angeles, Cleveland and Dallas to Time Warner Cable. These cable systems are presented as discontinued operations for the years ended on or before December 31, 2006 (see Note 5 to our audited consolidated financial statements included in the Annual Report on Form 10-K for the year ended December 31, 2006).

(3) Adjusted to reflect the three-for-two stock split in the form of a 50% stock dividend paid in February 2007.

	As of December 31					As of
	2002	2003	2004	2005	2006	March 31 2007 (unaudited)
	(in millions)					
Balance Sheet Data:						
Total assets	\$ 113,485	\$ 109,348	\$ 105,035	\$ 103,400	110,405	\$110,337
Long term debt, less current portion	27,956	23,835	20,093	21,682	27,992	27,222
Stockholders' equity	38,329	41,662	41,422	40,219	41,167	41,838

USE OF PROCEEDS

We intend to use the proceeds from this offering, after deducting fees and expenses related to this offering, for working capital and general corporate purposes, which may include funding repayment of commercial paper issued to repay, in part, \$600 million aggregate principal amount of our 8.375% notes due May 1, 2007. Our commercial paper has a weighted average interest rate of 5.358% and an average maturity of 10 days.

RATIO OF EARNINGS TO FIXED CHARGES

Our ratio of earnings to fixed charges was as follows for the respective periods indicated:

2002	Year Ended December 31					Three Months Ended March 31 2007
	2003	2004	2005	2006		
—(1)	—(1)	1.94x	1.92x	2.75x	3.37x	

(1) For the years ended December 31, 2003 and 2002, we had a \$88 million and \$470 million deficiency, respectively, of earnings to fixed charges.

For purposes of calculating the ratio of earnings to fixed charges, earnings is the amount resulting from (1) adding (a) pretax income from continuing operations before adjustment for minority interests in consolidated subsidiaries or income or loss from equity investees, (b) fixed charges, (c) amortization of capitalized interest, (d) distributed income of equity investees and (e) our share of pre-tax losses of equity investees for which charges arising from guarantees are included in fixed charges and (2) subtracting (i) interest capitalized, (ii) preference security dividend requirements of consolidated subsidiaries and (iii) the minority interest in pre-tax income of subsidiaries that have not incurred fixed charges. Fixed charges is the sum of (w) interest expensed and capitalized, (x) amortized premiums, discounts and capitalized expenses related to indebtedness, (y) an estimate of the interest within rental expense and (z) preference security dividend requirements of our consolidated subsidiaries. Preferred security dividend is the amount of pre-tax earnings that is required to pay the dividends on outstanding preference securities.

DESCRIPTION OF THE NOTES

We are offering \$ _____ aggregate principal amount of our _____ % Notes due 2056. The notes will be a separate series of securities issued under an indenture, dated as of January 7, 2003 and amended as of March 25, 2003, among us, the cable guarantors and The Bank of New York, as trustee. The notes will be our direct unsecured and unsubordinated obligations and will be fully and unconditionally guaranteed by Comcast Cable, Comcast Cable Communications Holdings, Comcast Cable Holdings, Comcast MO Group and Comcast MO of Delaware, referred to as the cable guarantors, as described below. The terms of the notes include those stated in the indenture and those made part of the indenture by reference to the Trust Indenture Act of 1939, as amended. The indenture provides that we will have the ability to issue securities with terms different from those of the notes. We also have the ability to “reopen” this series of notes and issue additional notes. Additional notes of such series will be consolidated with and form a single series with the notes then outstanding. Copies of the indenture and the form of notes are available from us upon request.

The following, along with the additional information contained in the accompanying prospectus under “Description of Debt Securities and Cable Guarantees,” is a summary of the material provisions of the indenture, the notes and the cable guarantees. Because this is a summary, it may not contain all the information that is important to you. For further information, you should read the notes and the indenture.

Basic Terms of the Notes

The notes:

- will rank equally with all of our other unsecured and unsubordinated debt and will be entitled to the benefits of the cable guarantees described below;
- will be issued in an initial aggregate principal amount of \$ _____ (\$ _____ if the underwriters exercise their overallotment option in full), maturing on May 15, 2056, with interest payable quarterly on each May 15, August 15, November 15 and February 15, beginning August 15, 2007, to holders of record on the preceding May 1, August 1, November 1 and February 1; and
- are issuable in fully registered form, in denominations of \$25.00 and multiples thereof.

Interest Payments

Interest on the notes will be computed on the basis of a 360-day year consisting of twelve 30-day months. Interest on the notes will accrue from the date of original issuance, or from the most recent interest payment date to which interest has been paid and will be payable quarterly on interest payment dates described for each year.

For more information on payment and transfer procedures for the notes, see “— Book-Entry System” below.

Cable Guarantees

Our obligations, including the payment of principal, premium, if any, and interest, will be fully and unconditionally guaranteed by each of the cable guarantors as described in the accompanying prospectus.

The cable guarantees will not contain any restrictions on the ability of any cable guarantor to (i) pay dividends or distributions on, or redeem, purchase, acquire, or make a liquidation payment with respect to, any of that cable guarantor’s capital stock or (ii) make any payment of principal, interest or premium, if any, on or repay, repurchase or redeem any debt securities of that cable guarantor.

Optional Redemption

We will have the right at our option to redeem the notes in whole or in part, at any time or from time to time on or after May 15, 2012 and prior to their maturity, on at least 30 days, but not more than 60 days, prior notice mailed to the registered address of each holder, at a redemption price equal to 100% of the principal amount of such notes, plus any accrued and unpaid interest thereon to the date of redemption.

On and after the redemption date, interest will cease to accrue on the notes or any portion of the notes called for redemption (unless we default in the payment of the redemption price and accrued interest). On or before the redemption date, we will deposit with the trustee money sufficient to pay the redemption price of and (unless the redemption date shall be an interest payment date) accrued and unpaid interest to the redemption date on the notes to be redeemed on such date. If less than all of the notes of any series are to be redeemed, the notes to be redeemed shall be selected by the trustee by such method as the trustee shall deem fair and appropriate. Additionally, we may at any time repurchase notes in the open market and may hold or surrender such notes to the trustee for cancellation.

Trading Characteristics

We intend to apply to list the notes on the New York Stock Exchange under the symbol “CCS”. If approved, we expect the notes to trade at a price that takes into account the value, if any, of accrued but unpaid interest. This means that purchasers will not pay, and sellers will not receive, accrued but unpaid interest on the notes that is not included in their trading price.

No Mandatory Redemption or Sinking Fund

There will be no mandatory redemption prior to maturity or sinking fund payments for the notes.

Additional Debt

The indenture does not limit the amount of debt we may issue under the indenture or otherwise.

Book-Entry System

We will initially issue the notes in the form of one or more global notes (the “Global Notes”). The Global Notes will be deposited with, or on behalf of, The Depository Trust Company (“DTC”) and registered in the name of DTC or its nominee. Except as set forth below, the Global Notes may be transferred, in whole and not in part, only to DTC or another nominee of DTC. A holder may hold beneficial interests in the Global Notes directly through DTC if such holder has an account with DTC or indirectly through organizations which have accounts with DTC, including Euroclear and Clearstream.

DTC

DTC has advised us as follows: DTC is a limited purpose trust company organized under the laws of the State of New York, a member of the Federal Reserve System, a clearing corporation within the meaning of the New York Uniform Commercial Code and a clearing agency registered pursuant to the provisions of Section 17A of the Exchange Act. DTC was created to hold securities of institutions that have accounts with DTC (“participants”) and to facilitate the clearance and settlement of securities transactions among its participants in such securities through electronic book-entry changes in accounts of the participants, thereby eliminating the need for physical movement of securities certificates. DTC’s participants include securities brokers and dealers, banks, trust companies, clearing corporations and certain other organizations. Access to DTC’s book-entry system is also available to others such as banks, brokers, dealers and trust companies (collectively, the “indirect participants”) that clear through or maintain a custodial relationship with a participant, whether directly or indirectly.

We expect that pursuant to procedures established by DTC, upon the deposit of the Global Notes with DTC, DTC will credit on its book-entry registration and transfer system the principal amount of notes represented by such Global Notes to the accounts of participants. Ownership of beneficial interests in the Global Notes will be limited to participants or persons that may hold interests through participants. Ownership of beneficial interests in the Global Notes will be shown on and the transfer of those ownership interests will be effected only through, records maintained by DTC (with respect to participants’ interests), the participants and the indirect participants (with respect to the owners of beneficial interests in the Global Note other than participants). All interests in a Global Note deposited with DTC are subject to the procedures and requirements of DTC.

The laws of some jurisdictions may require that certain purchasers of securities take physical delivery of such securities in definitive form. Such limits and laws may impair the ability to transfer or pledge beneficial interests in the Global Notes.

So long as DTC (or its nominee) is the registered holder and owner of a Global Note, DTC (or such nominee) will be considered the sole legal owner and holder of the notes evidenced by such Global Note for all purposes of such notes and the indenture. Except as set forth below under “— Certificated Notes,” as an owner of a beneficial interest in a Global Note, you will not be entitled to have the notes represented by such Global Note registered in your name, will not receive or be entitled to receive physical delivery of certificated notes and will not be considered to be the owner or holder of any notes under such Global Note. We understand that under existing industry practice, in the event an owner of a beneficial interest in a Global Note desires to take any action that DTC, as the holder of such Global Note, is entitled to take, DTC would authorize the participants to take such action, and the participants would authorize beneficial owners owning through such participants to take such action or would otherwise act upon the instructions of beneficial owners owning through them.

We will make payments of principal of, premium, if any, and interest on the notes represented by the Global Notes registered in the name of and held by DTC or its nominee to DTC or its nominee, as the case may be, as the registered owner and holder of the Global Notes.

We expect that DTC (or its nominee), upon receipt of any payment of principal of, premium, if any, or interest on the Global Notes will credit the accounts of their relevant participants or account holders, as applicable, with payments in amounts proportionate to their respective beneficial interests in the principal amount of the applicable Global Note as shown on the records of DTC (or its nominee). We also expect that payments by participants or indirect participants or account holders, as applicable, to owners of beneficial interests in the Global Notes held through such participants or indirect participants or account holders will be governed by standing instructions and customary practices and will be the responsibility of such participants or indirect participants or account holders, as applicable. We will not have any responsibility or liability for any aspect of the records relating to, or payments made on account of, beneficial ownership interests in the Global Notes for any notes or for maintaining, supervising or reviewing any records relating to such beneficial ownership interests or for any other aspect of the relationship between DTC and its participants or indirect participants, or the relationship between such participants or indirect participants, and the owners of beneficial interests in the Global Notes owning through such participants.

All amounts payable under the notes will be payable in U.S. dollars, except as may otherwise be agreed between any applicable securities clearing system and any holders. Payments will be subject in all cases to any fiscal or other laws and regulations (including any regulations of any applicable securities clearing system) applicable thereto. None of the trustee, us, the cable guarantors or any of our or their respective agents shall be liable to any holder of a Global Note or other person for any commissions, costs, losses or expenses in relation to or resulting from any currency conversion or rounding effected in connection therewith. Investors may be subject to foreign exchange risks that may have important economic and tax consequences to them.

Certificated Notes

Subject to certain conditions, the notes represented by the Global Notes are exchangeable for certificated notes in definitive form of like tenor in denominations of \$25.00 principal amount and multiples thereof if:

- (1) DTC provides notification that it is unwilling or unable to continue as depository for the Global Notes or DTC ceases to be a clearing agency registered under the Exchange Act and, in either case, a successor is not appointed within 90 days;
- (2) we in our discretion at any time determine not to have all the notes represented by the Global Notes; or
- (3) a default entitling the holders of the applicable notes to accelerate the maturity thereof has occurred and is continuing.

Any note that is exchangeable as above is exchangeable for certificated notes issuable in authorized denominations and registered in such names as DTC shall direct. Subject to the foregoing, a Global Note is not exchangeable, except for a Global Note of the same aggregate denomination to be registered in the name of DTC (or its nominee).

Same-Day Payment

The indenture requires payments to be made in respect of the applicable notes represented by the Global Notes (including principal, premium and interest) by wire transfer of immediately available funds to the accounts specified by the holder thereof or, if no such account is specified, by mailing a check to such holder's registered address.

Payments (including principal, premium and interest) and transfers with respect to notes in certificated form may be executed at the office or agency maintained for such purpose within the City and State of New York (initially the office of the paying agent maintained for such purpose) or, at our option, by check mailed to the holders thereof at the respective addresses set forth in the register of holders of the applicable notes, provided that all payments (including principal, premium and interest) on notes in certificated form, for which the holders thereof have given wire transfer instructions, will be required to be made by wire transfer of immediately available funds to the accounts specified by the holders thereof. No service charge will be made for any registration of transfer, but payment of a sum sufficient to cover any tax or governmental charge payable in connection with that registration may be required.

MATERIAL U.S. FEDERAL INCOME TAX CONSEQUENCES FOR NON-U.S. HOLDERS

The following are the material U.S. federal income tax consequences of ownership and disposition of the notes. This discussion only applies to notes that meet all of the following conditions:

- they are purchased by those initial holders who purchase notes at the “issue price,” which will equal the first price to the public (not including bond houses, brokers or similar persons or organizations acting in the capacity of underwriters, placement agents or wholesalers) at which a substantial amount of the notes is sold for money;
- they are held as capital assets; and
- they are beneficially owned by Non-U.S. Holders (as defined below).

This discussion does not describe all of the tax consequences that may be relevant to holders in light of their particular circumstances or to holders subject to special rules, such as:

- certain financial institutions;
- tax exempt entities;
- insurance companies;
- persons liable for the alternative minimum tax;
- dealers in securities or foreign currencies;
- persons holding notes as part of a hedge, straddle or other integrated transaction; or
- partnerships or other entities classified as partnerships for U.S. federal income tax purposes.

This summary is based on the Internal Revenue Code of 1986, as amended to the date hereof, administrative pronouncements, judicial decisions and final, temporary and proposed Treasury Regulations, changes to any of which subsequent to the date of this prospectus supplement may affect the tax consequences described herein. Persons considering the purchase of notes are urged to consult their tax advisers with regard to the application of the U.S. federal tax laws to their particular situations as well as any tax consequences arising under the laws of any state, local or foreign taxing jurisdiction.

As used herein, the term “Non-U.S. Holder” means a beneficial owner of a note that is, for U.S. federal income tax purposes:

- an individual who is classified as a nonresident for U.S. federal income tax purposes;
- a foreign corporation; or
- a foreign estate or trust.

“Non-U.S. Holder” does not include a holder who is an individual present in the United States for 183 days or more in the taxable year of disposition. Such a holder is urged to consult his or her own tax advisor regarding the U.S. federal income tax consequences of the sale, exchange or other disposition of a note.

Subject to the discussion below concerning backup withholding:

- payments of principal and interest on the notes by us or any paying agent to any Non-U.S. Holder will not be subject to U.S. federal withholding tax, provided that, in the case of interest not effectively connected with the conduct of a trade or business in the United States,
 - the holder does not own, actually or constructively, 10 percent or more of the total combined voting power of all classes of our stock entitled to vote and is not a controlled foreign corporation related, directly or indirectly, to us through stock ownership; and
 - the certification requirement described below has been fulfilled with respect to the beneficial owner, as discussed below;

- a Non-U.S. Holder of a note will not be subject to U.S. federal income tax on gain realized on the sale, exchange or other disposition of such note, unless the gain is effectively connected with the conduct by the holder of a trade or business in the United States, subject to an applicable income tax treaty providing otherwise.

Certification Requirement

Interest not effectively connected with the conduct of a trade or business in the United States will not be exempt from withholding tax unless the beneficial owner of that note certifies on Internal Revenue Service Form W-8BEN, under penalties of perjury, that it is not a U.S. person.

Effectively Connected Income

If a Non-U.S. Holder of a note is engaged in a trade or business in the United States, and if interest on or gain with respect to the note is effectively connected with the conduct of this trade or business, the Non-U.S. Holder, although exempt from the withholding tax discussed in the preceding paragraph, will generally be taxed in the same manner as a U.S. person, subject to an applicable income tax treaty providing otherwise, except that the holder will be required to provide to us a properly executed Internal Revenue Service Form W-8ECI in order to claim an exemption from withholding tax with respect to interest. These holders should consult their own tax advisors with respect to other U.S. tax consequences of the ownership and disposition of notes including the possible imposition of an additional 30% branch profits tax.

Backup Withholding and Information Reporting

Information returns will be filed with the U.S. Internal Revenue Service in connection with payments on the notes. Unless the Non-U.S. Holder complies with certification procedures to establish that it is not a U.S. person, information returns may be filed with the U.S. Internal Revenue Service in connection with the proceeds from a sale or other disposition and the Non-U.S. Holder may be subject to U.S. backup withholding tax on payments on the notes or on the proceeds from a sale or other disposition of the notes. The certification procedures required to claim the exemption from withholding tax on interest described above will satisfy the certification requirements necessary to avoid the backup withholding tax as well. The amount of any backup withholding from a payment to a Non-U.S. Holder will be allowed as a credit against the Non-U.S. Holder's U.S. federal income tax liability and may entitle the Non-U.S. Holder to a refund, provided that the required information is timely furnished to the Internal Revenue Service.

UNDERWRITING

Citigroup Global Markets Inc. and Merrill Lynch, Pierce, Fenner & Smith Incorporated are acting as joint book-running managers of the offering and are acting as representatives of the underwriters named below.

We intend to offer the notes through the underwriters named below. Subject to the terms and conditions contained in an underwriting agreement, we have agreed to sell to the underwriters and the underwriters severally have agreed to purchase from us, the principal amount of the notes listed opposite their names below.

<u>Underwriter</u>	<u>Principal Amount of Notes</u>
Citigroup Global Markets Inc.	
Merrill Lynch, Pierce, Fenner & Smith Incorporated	
Morgan Stanley & Co. Incorporated	
UBS Securities LLC	
Wachovia Capital Markets, LLC	
A.G. Edwards & Sons, Inc.	
RBC Dain Rauscher Inc.	
Banc of America Securities LLC	
Deutsche Bank Securities Inc.	
Lehman Brothers Inc.	
J.P. Morgan Securities Inc.	
Barclays Capital Inc.	
Bear, Stearns & Co. Inc.	
H&R Block Financial Advisors, Inc.	
Credit Suisse Securities (USA) LLC	
Goldman, Sachs & Co.	
J.J.B. Hilliard, W.L. Lyons, Inc.	
HSBC Securities (USA) Inc.	
Janney Montgomery Scott LLC	
KeyBanc Capital Markets, a division of McDonald Investments Inc.	
Oppenheimer & Co. Inc.	
Piper Jaffray & Co.	
Raymond James & Associates, Inc.	
Charles Schwab & Co., Inc.	
TD Ameritrade, Inc.	
Wells Fargo Securities, LLC	
Robert W. Baird & Co. Incorporated	
William Blair & Company, L.L.C.	
BB&T Capital Markets, a division of Scott & Stringfellow, Inc.	
Crowell, Weedon & Co.	
Davenport & Company LLC	
D.A. Davidson & Co.	
Doley Securities, LLC.	
Ferris, Baker Watts, Incorporated	
Fixed Income Securities	
Guzman & Company	
Jackson Securities, LLC	

<u>Underwriter</u>	<u>Principal Amount of Notes</u>
Jefferies & Company, Inc.	
Keefe, Bruyette & Woods, Inc.	
Loop Capital Markets, LLC	
Mesirow Financial, Inc.	
Morgan Keegan & Company, Inc.	
Pershing LLC	
Samuel A. Ramirez & Co., Inc.	
Ryan Beck & Co., Inc.	
Stifel, Nicolaus & Company, Incorporated	
Stone & Youngberg LLC	
SunTrust Capital Markets, Inc.	
Wedbush Morgan Securities Inc.	
The Williams Capital Group, L.P.	
B.C. Ziegler and Company	
Total	\$

The underwriters have agreed to purchase all of the notes sold pursuant to the underwriting agreement if any of these notes are purchased. If an underwriter defaults, the underwriting agreement provides that the purchase commitments of the nondefaulting underwriters may be increased or the underwriting agreement may be terminated.

We have agreed to indemnify the underwriters against certain liabilities, including liabilities under the Securities Act of 1933, as amended, or to contribute to payments the underwriters may be required to make in respect of those liabilities.

The underwriters are offering the notes, subject to prior sale, when, as and if issued to and accepted by them, subject to approval of legal matters by their counsel, including the validity of the notes, and other conditions contained in the underwriting agreement, such as the receipt by the underwriters of officer's certificates and legal opinions. The underwriters reserve the right to withdraw, cancel or modify offers to the public and to reject orders in whole or in part.

Selling Restrictions

General

The notes are being offered for sale in the United States and in jurisdictions outside the United States, subject to applicable law. Each of the underwriters has agreed that it will not offer, sell or deliver any of the notes, directly or indirectly, or distribute this prospectus supplement or the accompanying prospectus or any other offering material relating to the notes, in or from any jurisdiction except under circumstances that will to the best knowledge and belief of such underwriter result in compliance with the applicable laws and regulations thereof and which will not impose any obligations on us except as set forth in the underwriting agreement.

European Union Prospectus Directive

Each underwriter has represented, warranted and agreed that in relation to each Member State of the European Economic Area which has implemented the Prospectus Directive (each, a "Relevant Member State"), with effect from and including the date on which the Prospectus Directive is implemented in that Relevant Member State (the "Relevant Implementation Date"), it has not made and will not make an offer of notes to the public in that Relevant Member State prior to the publication of a prospectus in relation to the notes which has been approved by the competent authority in that Relevant Member State or, where appropriate, approved in another Relevant Member State and notified to the competent authority in that Relevant Member State, all

in accordance with the Prospectus Directive, except that it may, with effect from and including the Relevant Implementation Date, make an offer of notes to the public in that Relevant Member State at any time:

- (i) to legal entities which are authorized or regulated to operate in the financial markets or, if not so authorized or regulated, whose corporate purpose is solely to invest in securities;
- (ii) to any legal entity which has two or more of (1) an average of at least 250 employees during the last financial year; (2) a total balance sheet of more than €43,000,000 and (3) an annual net turnover of more than €50,000,000, as shown in its last annual or consolidated accounts; or
- (iii) in any other circumstances which do not require the publication by the Issuer of a prospectus pursuant to Article 3 of the Prospectus Directive.

For the purposes of this provision, the expression “an offer of notes to the public” in relation to any notes in any Relevant Member State means the communication in any form and by any means of sufficient information on the terms of the offer and the notes to be offered so as to enable an investor to decide to purchase or subscribe the notes, as the same may be varied in that Member State by any means implementing the Prospectus Directive in that Member State, and the expression “Prospectus Directive” means Directive 2003/71/EC and includes any relevant implementing measure in each Relevant Member State.

United Kingdom

Each underwriter has represented, warranted and agreed that it has only communicated or caused to be communicated and will only communicate or cause to be communicated an invitation or inducement to engage in investment activity (within the meaning of Section 21 of the U.K. Financial Services and Markets Act 2000 (“FSMA”)) received by it in connection with the issue or sale of the notes in circumstances in which Section 21(1) of FSMA does not apply to the Issuer or the cable guarantors; and it has complied with and will comply with all applicable provisions of FSMA with respect to anything done by it in relation to the notes in, from or otherwise involving the United Kingdom.

Hong Kong

The notes may not be offered or sold by means of any document other than to persons whose ordinary business is to buy or sell shares or debentures, whether as principal or agent, or in circumstances which do not constitute an offer to the public within the meaning of the Companies Ordinance (Cap. 32) of Hong Kong, and no advertisement, invitation or document relating to the notes may be issued, whether in Hong Kong or elsewhere, which is directed at, or the contents of which are likely to be accessed or read by, the public in Hong Kong (except if permitted to do so under the securities laws of Hong Kong) other than with respect to notes which are or are intended to be disposed of only to persons outside Hong Kong or only to “professional investors” within the meaning of the Securities and Futures Ordinance (Cap. 571) of Hong Kong and any rules made thereunder.

Japan

The notes have not been and will not be registered under the Securities and Exchange Law of Japan, and each of the underwriters and each of its affiliates has represented and agreed that it has not offered or sold, and it will not offer or sell, directly or indirectly, any of the notes in or to residents of Japan or to any persons for reoffering or resale, directly or indirectly in Japan or to any resident of Japan, except pursuant to any exemption from the registration requirements of the Securities and Exchange Law available thereunder and in compliance with the other relevant laws and regulations of Japan.

Singapore

This prospectus supplement has not been registered as a prospectus with the Monetary Authority of Singapore. Accordingly, this prospectus supplement and any other document or material in connection with the offer or sale, or invitation for subscription or purchase, of the notes may not be circulated or distributed, nor

Table of Contents

may the notes be offered or sold, or be made the subject of an invitation for subscription or purchase, whether directly or indirectly, to persons in Singapore other than:

- (i) to an institutional investor under Section 274 of the Securities and Futures Act, Chapter 289 of Singapore (the “SFA”);
- (ii) to a relevant person, or any person pursuant to Section 257(1A), and in accordance with the conditions, specified in Section 275 of the SFA; or
- (iii) otherwise pursuant to, and in accordance with the conditions of, any other applicable provision of the SFA.

Whether the notes are subscribed or purchased under Section 275 by a relevant person which is:

- (a) a corporation (which is not an accredited investor) the sole business of which is to hold investments and the entire share capital of which is owned by one or more individuals, each of whom is an accredited investor; or
- (b) a trust (where the trustee is not an accredited investor) whose sole purpose is to hold investments and each beneficiary is an accredited investor, shares, debentures, and units of shares and debentures of that corporation or the beneficiaries’ rights and interest in that trust shall not be transferable for six months after that corporation or that trust has acquired the notes under Section 275 except: (1) to an institutional investor under Section 274 of the SFA or to a relevant person, or any person pursuant to Section 275(1A), and in accordance with the conditions, specified in Section 275 of the SFA; (2) where no consideration is given for the transfer; or (3) by operation of law.

Over-Allotment Option

We have granted to the underwriters an option, exercisable for 15 days from the date of this prospectus supplement, to purchase up to an additional \$ aggregate principal amount of notes at the public offering price less the underwriting discount. The underwriters may exercise the option solely for the purpose of covering over-allotments, if any, in connection with this offering. To the extent the option is exercised, each underwriter must purchase a number of additional notes approximately proportionate to that underwriter’s initial purchase commitment. If the underwriters exercise their over-allotment option in full the total price to the public would be \$, the total underwriting discounts and commissions would be \$ and the total proceeds, before deducting expenses, to us would be \$.

Commissions and Discounts

The underwriters have advised us that they propose initially to offer the notes to the public at the public offering price on the cover page of this prospectus supplement, and to dealers at that price less a concession not in excess of \$ per note for retail orders and \$ per note for institutional orders. The underwriters may allow, and the dealers may reallow, a discount not in excess of \$ per note to other dealers. After the initial public offering, the public offering prices, concessions and discounts may be changed.

The expenses of the offering, not including the underwriting discount, are estimated to be \$300,000 and are payable by us.

The following table shows the underwriting discounts and commissions that we are to pay to the underwriters in connection with this offering. These amounts are shown assuming both no exercise and full exercise of the underwriters’ option to purchase additional notes.

	<u>No Exercise</u>	<u>Full Exercise</u>
Per note (retail orders)	\$	\$
Per note (institutional orders)	\$	\$
Total	\$	\$

New Issue of Notes

The notes are a new issue of securities with no established trading market. We intend to apply to list the notes on the New York Stock Exchange under the symbol “CCS”, and we expect trading in the notes on the New York Stock Exchange to begin within 30 days after the original issue date. We have been advised by the

underwriters that they presently intend to make a market in the notes after completion of the offering. However, they are under no obligation to do so and may discontinue any market-making activities at any time without any notice. We cannot assure the liquidity of the trading market for the notes or that an active public market for the notes will develop. If an active public trading market for the notes does not develop, the market price and liquidity of the notes may be adversely affected.

Price Stabilization and Short Positions

In connection with the offering, the underwriters are permitted to engage in transactions that stabilize the market price of the notes. These stabilization transactions consist of bids or purchases to peg, fix or maintain the price of the notes. Specifically, the underwriters may sell a principal amount of notes greater than they are obligated to purchase under the underwriting agreement, creating a short position. A short sale is covered if the short position is no greater than the principal amount of notes available for purchase by the underwriters under the over-allotment option. The underwriters can close out a covered short sale by exercising the over-allotment option or purchasing notes in the open market. In determining the source of notes to close out a covered short sale, the underwriters will consider, among other things, the open market price of shares compared to the price available under the over-allotment option. The underwriters may also sell a principal amount of notes in excess of the over-allotment option, creating a naked short position. The underwriters must close out any naked short position by purchasing notes in the open market. A naked short position is more likely to be created if the underwriters are concerned that there may be downward pressure on the price of the notes in the open market after pricing that could adversely affect investors who purchase in this offering. As an additional means of facilitating this offering, the underwriters may bid for, and purchase, notes in the open market to stabilize the price of the notes. Purchases of a security to stabilize the price or to reduce a short position could cause the price of the security to be higher than it might be in the absence of such purchases.

Neither we nor any of the underwriters makes any representation or prediction as to the direction or magnitude of any effect that the transactions described above may have on the price of the notes. In addition, neither we nor any of the underwriters makes any representation that the underwriters will engage in these transactions or that these transactions, once commenced, will not be discontinued without notice.

Alternative Settlement Date

It is expected that delivery of the notes will be made on or about the date specified on the cover page of this prospectus supplement, which will be the fifth business day following the date of this prospectus supplement. Under Rule 15c6-1 of the Securities and Exchange Commission under the Securities Exchange Act of 1934, as amended, trades in the secondary market generally are required to settle in three business days, unless the parties to any such trade expressly agree otherwise. Accordingly, the purchasers who wish to trade notes on the date of this prospectus supplement or the next succeeding business day will be required to specify an alternate settlement cycle at the time of any such trade to prevent failed settlement. Purchasers of notes who wish to trade notes on the date of this prospectus supplement or the next succeeding business day should consult their own advisors.

Other Relationships

The underwriters and their affiliates have engaged in, and may in the future engage in, investment banking and other commercial dealings in the ordinary course of business with us. They have received, and may receive, customary fees and commissions for these transactions.

Dr. Judith Rodin, our director, is a member of the board of directors of Citigroup Inc., an affiliate of Citigroup Global Markets Inc.

LEGAL MATTERS

Various legal matters relating to the offering will be passed upon for us by Arthur R. Block, Esquire, Senior Vice President and General Counsel of Comcast Corporation, Thomas R. Nathan, Esquire, Senior Vice President of the cable guarantors, and by Davis Polk & Wardwell, Menlo Park, California. Cahill Gordon & Reindel LLP, New York, New York, is representing the underwriters.

PROSPECTUS



The following are types of securities that may be offered and sold under this prospectus:

- Unsecured senior debt securities
- Unsecured subordinated debt securities
- Warrants
- Purchase contracts
- Units
- Preferred Stock
- Depositary shares
- Class A Common Stock
- Class A Special Common Stock

If indicated in the relevant prospectus supplement, the securities may be fully and unconditionally guaranteed by a number of our wholly-owned cable subsidiaries named in this prospectus.

Our Class A Common Stock and Class A Special Common Stock are quoted on The Nasdaq National Market under the ticker symbols "CMCSA" and "CMCSK". On March 27, 2006, the reported last sale prices on The Nasdaq National Market for our Class A Common Stock and our Class A Special Common Stock were \$26.72 and \$26.64.

We will describe in a prospectus supplement, which must accompany this prospectus, the securities we are offering and selling, as well as the specific terms of the securities. Those terms may include:

- | | | |
|------------------------|------------------------------------|---------------------------------|
| • Maturity | • Redemption terms | • Conversion or exchange rights |
| • Interest rate | • Listing on a securities exchange | • Liquidation amount |
| • Sinking fund terms | • Amount payable at maturity | • Subsidiary guarantees |
| • Currency of payments | • Dividends | |

Investing in these securities involves certain risks. See "Item 1A — Risk Factors" beginning on page 18 of our annual report on Form 10-K for the year ended December 31, 2005 which is incorporated by reference herein.

The Securities and Exchange Commission and state securities regulators have not approved or disapproved of these securities, or determined if this prospectus is truthful or complete. Any representation to the contrary is a criminal offense.

We may offer the securities in amounts, at prices and on terms determined at the time of offering. We may sell the securities directly to you, through agents we select, or through underwriters and dealers we select. If we use agents, underwriters or dealers to sell the securities, we will name them and describe their compensation in a prospectus supplement.

The date of this prospectus is March 27, 2006

Comcast Corporation (simplified)

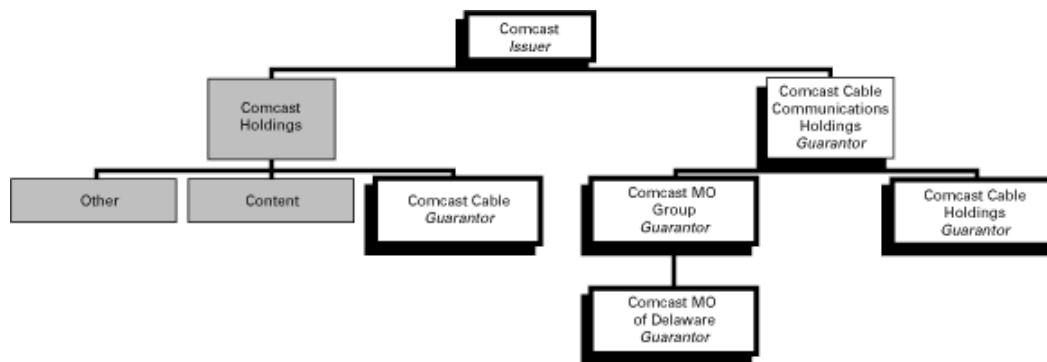

- Comcast Corporation, referred to as "Comcast."
 - Comcast Cable Communications, LLC (formerly known as Comcast Cable Communications, Inc.), referred to as "Comcast Cable."
 - Comcast Cable Communications Holdings, Inc. (formerly known as AT&T Broadband Corp.), referred to as "Comcast Cable Communications Holdings" or "Broadband."
 - Comcast MO Group, Inc. (formerly known as MediaOne Group, Inc.), referred to as "Comcast MO Group."
 - Comcast Cable Holdings, LLC (formerly known as AT&T Broadband, LLC and Tele-Communications, Inc.), referred to as "Comcast Cable Holdings."
 - Comcast MO of Delaware, LLC (formerly known as Media One of Delaware, Inc. and Continental Cablevision, Inc.), referred to as "Comcast MO of Delaware."
-

Table of Contents

	<u>Page</u>
The Companies	1
Caution Concerning Forwardlooking Statements	3
Use of Proceeds	3
Dividend Policy	3
Ratios of Earnings to Fixed Charges	3
Ratio of Earnings to Combined Fixed Charges and Preferred Dividends	4
Description of Debt Securities and Cable Guarantees	5
Global Securities	18
Description of Capital Stock	20
Plan of Distribution	24
Legal Matters	25
Experts	25
Available Information	25
Incorporation of Certain Documents by Reference	26

You should rely only on the information contained in or incorporated by reference in this prospectus. We have not authorized anyone to provide you with different information. We are not making an offer of these securities in any state where the offer is not permitted. You should not assume that the information contained in or incorporated by reference in this prospectus is accurate as of any date other than the date on the front of this prospectus.

We refer to Comcast Corporation in this prospectus as “Comcast” or “we,” “us,” “our” or comparable terms and to Comcast Holdings Corporation as “Comcast Holdings.” We refer to Comcast Cable Communications, LLC, Comcast Cable Communications Holdings, Inc., Comcast Cable Holdings, LLC, Comcast MO Group, Inc. and Comcast MO of Delaware, LLC collectively as the “Cable Guarantors.”

THE COMPANIES

Comcast Corporation

We are the largest broadband cable provider in the United States and offer a wide variety of consumer entertainment and communication products and services. As of December 31, 2005, we served more than 21 million video subscribers, 8 million high-speed Internet subscribers and 1 million phone subscribers. We were incorporated under the laws of Pennsylvania in December 2001. Through our predecessors (including our immediate predecessor Comcast Holdings), we have developed, managed and operated broadband cable systems since 1963.

We manage our operations through two reportable segments, "Cable" and "Content". The Cable segment generates approximately 95% of our consolidated revenues.

Our Cable segment develops, manages and operates our broadband cable systems, including video, high-speed Internet and phone services.

Our Content segment includes our six national cable networks: E! Entertainment Television, Style Network, The Golf Channel, OLN, G4, and AZN Television.

Our other business interests include Comcast Spectacor, which owns the Philadelphia Flyers, the Philadelphia 76ers and two large multipurpose arenas in Philadelphia, and manages other facilities for sporting events, concerts and other events.

For a description of our business, financial condition, results of operations and other important information regarding us, see our filings with the SEC incorporated by reference in this prospectus. For instructions on how to find copies of these and our other filings incorporated by reference in this prospectus, see "Available Information" in the accompanying prospectus.

Cable Guarantors

Our obligations, including the payment of principal, premium, if any, and interest on the debt securities issued pursuant to this prospectus will be fully and unconditionally guaranteed by each of Comcast Cable, Comcast Cable Communications Holdings, Comcast Cable Holdings, Comcast MO Group and Comcast MO of Delaware. In this prospectus, we refer to these guarantors as the cable guarantors and to these guarantees as the cable guarantees. We have numerous other subsidiaries that will not be guarantors on the debt securities. If indicated in the relevant prospectus supplement, our obligations under the other securities we are offering and selling may be fully and unconditionally guaranteed by specified cable guarantors.

The cable guarantees will not contain any restrictions on the ability of any cable guarantor to:

- pay dividends or distributions on, or redeem, purchase, acquire, or make a liquidation payment with respect to, any of that cable guarantor's capital stock; or
- make any payment of principal, interest or premium, if any, on or repay, repurchase or redeem any debt securities of that cable guarantor.

Comcast Cable Communications, LLC

Comcast Cable, which was incorporated in 1981 as a Delaware corporation, became a Delaware limited liability company in 2003 and is an indirect wholly-owned subsidiary of ours.

Comcast Cable Communications Holdings, Inc.

Comcast Cable Communications Holdings is a Delaware corporation (formerly known as AT&T Broadband Corp.) incorporated in 2001 and a wholly-owned subsidiary of ours.

Comcast Cable Holdings, LLC

Comcast Cable Holdings is a Delaware limited liability company (formerly known as AT&T Broadband, LLC) formed in 1994. Comcast Cable Holdings is a wholly-owned subsidiary of Comcast Cable Communications Holdings.

Comcast MO Group, Inc.

Comcast MO Group is a Delaware corporation (formerly known as MediaOne Group, Inc.) incorporated in 1999. Comcast MO Group is a wholly-owned subsidiary of Comcast Cable Communications Holdings.

Comcast MO of Delaware, LLC

Comcast MO of Delaware, which was incorporated in 1996 as a Delaware corporation, became a Delaware limited liability company in 2003. Comcast MO of Delaware is an indirect wholly-owned subsidiary of Comcast MO Group.

Our principal executive offices are located at 1500 Market Street, Philadelphia, Pennsylvania 19102-2148, and our telephone number is (215) 665-1700. We maintain a website at <http://www.comcast.com> where general information about us is available. We are not incorporating the contents of the website into this prospectus.

Each cable guarantor's principal place of business is 1500 Market Street, Philadelphia, Pennsylvania 19102-2148.

CAUTION CONCERNING FORWARD-LOOKING STATEMENTS

Our businesses may be affected by, among other things, the following:

- All of the services offered by our cable systems face a wide range of competition that could adversely affect our future results of operations.
- Programming costs are increasing, which could adversely affect our future results of operations.
- We are subject to regulation by federal, state and local governments, which may change and cause increased costs and restrictions.
- We may face increased competition because of technological advances and changing regulatory requirements, which could adversely affect our future results of operations.
- We face risks arising from the outcome of various litigation matters, including litigation associated with our acquisition of AT&T's Broadband operations.
- Our Chairman and CEO has considerable influence over our operations.
- Acquisitions and other strategic transactions present many risks, and we may not realize the financial and strategic goals that were contemplated at the time of any transaction.

In this prospectus and in the documents we incorporate by reference, we state our expectations of future events and our future financial performance. In some cases, you can identify those so-called "forward-looking statements" by words such as "may," "will," "should," "expects," "plans," "anticipates," "believes," "estimates," "predicts," "potential," or "continue" or the negative of those words and other comparable words. You should be aware that those statements are only our predictions. Actual events or results may differ materially. In evaluating those statements, you should specifically consider various factors, including the risks outlined under "Item 1A — Risk Factors" in our Annual Report on Form 10-K for the year ended December 31, 2005 incorporated herein by reference. Those factors may cause our actual results to differ materially from any of our forward-looking statements.

USE OF PROCEEDS

We intend to use the net proceeds from the sale of the securities for working capital and general corporate purposes. We may also invest the proceeds in certificates of deposit, United States government securities or certain other interest-bearing securities. If we decide to use the net proceeds from a particular offering of securities for a specific purpose, we will describe that in the related prospectus supplement.

DIVIDEND POLICY

We do not intend to pay dividends on our common stock for the foreseeable future.

RATIOS OF EARNINGS TO FIXED CHARGES

Our ratio of earnings to fixed charges was as follows for the respective periods indicated:

	For the Years Ended December 31,			
<u>2005</u>	<u>2004</u>	<u>2003</u>	<u>2002</u>	<u>2001</u>
2.01x	1.97x	—(1)	—(1)	1.33x

- (1) For the years ended December 31, 2003 and 2002, we had a \$76 million and \$490 million deficiency, respectively, of earnings to fixed charges.

For purposes of calculating the ratio of earnings to fixed charges, earnings is the amount resulting from (1) adding (a) pretax income from continuing operations before adjustment for minority interests in consolidated subsidiaries or income or loss from equity investees, (b) fixed charges, (c) amortization of capitalized interest, (d) distributed income of equity investees and (e) our share of pre-tax losses of equity investees for which charges arising from guarantees are included in fixed charges and (2) subtracting (i) interest capitalized, (ii) preference security dividend requirements of consolidated subsidiaries and (iii) the minority interest in pre-tax income of subsidiaries that have not incurred fixed charges. Fixed charges is the sum of (w) interest expensed and capitalized, (x) amortized premiums, discounts and capitalized expenses related to indebtedness, (y) an estimate of the interest within rental expense and (z) preference security dividend requirements of our consolidated subsidiaries. Preferred security dividend is the amount of pre-tax earnings that is required to pay the dividends on outstanding preference securities.

**RATIOS OF EARNINGS TO COMBINED FIXED CHARGES
AND PREFERRED DIVIDENDS**

<u>For the Years Ended December 31,</u>				
<u>2005</u>	<u>2004</u>	<u>2003</u>	<u>2002</u>	<u>2001</u>
2.01x	1.97x	—(1)	—(1)	1.33x

- (1) For the years ended December 31, 2003 and 2002, we had a \$76 million and \$490 million deficiency, respectively, of earnings to combined fixed charges and preferred dividends.

For purposes of calculating the ratio of earnings to combined fixed charges and preferred dividends, earnings is the amount resulting from (1) adding (a) pretax income from continuing operations before adjustment for minority interests in consolidated subsidiaries or income or loss from equity investees, (b) fixed charges, (c) amortization of capitalized interest, (d) distributed income of equity investees and (e) our share of pre-tax losses of equity investees for which charges arising from guarantees are included in fixed charges and (2) subtracting (i) interest capitalized, (ii) preference security dividend requirements of consolidated subsidiaries and (iii) the minority interest in pre-tax income of subsidiaries that have not incurred fixed charges. Fixed charges is the sum of (w) interest expensed and capitalized, (x) amortized premiums, discounts and capitalized expenses related to indebtedness, (y) an estimate of the interest within rental expense and (z) preference security dividend requirements of our consolidated subsidiaries. Preferred security dividend is the amount of pre-tax earnings that is required to pay the dividends on outstanding preference securities.

DESCRIPTION OF DEBT SECURITIES AND CABLE GUARANTEES

Our debt securities, consisting of notes, debentures or other evidences of indebtedness, may be issued from time to time in one or more series:

- in the case of senior debt securities, under a senior indenture dated January 7, 2003, as amended by a supplemental indenture dated March 25, 2003, entered into among us, the cable guarantors and The Bank of New York, as trustee; and
- in the case of subordinated debt securities, under a subordinated indenture to be entered into among us, the cable guarantors and The Bank of New York, as trustee.

The senior indenture and supplemental indenture are included, and the subordinated indenture will be substantially in the form included, as exhibits to the registration statement of which this prospectus is a part.

Because the following is only a summary of the indentures and the debt securities, it does not contain all information that you may find useful. For further information about the indentures and the debt securities, you should read the indentures. As used in this section of the prospectus and under the caption “Description of Common Stock,” the terms “we,” “us” and “our” refer solely to Comcast Corporation and such references do not include any subsidiaries of Comcast Corporation.

General

The senior debt securities will constitute our unsecured and unsubordinated obligations and the subordinated debt securities will constitute our unsecured and subordinated obligations. A detailed description of the subordination provisions is provided below under the caption “—Certain Terms of the Subordinated Debt Securities—Subordination.” In general, however, if we declare bankruptcy, holders of the senior debt securities will be paid in full before the holders of subordinated debt securities will receive anything. The debt securities will be fully and unconditionally guaranteed by the cable guarantors, as described below. The debt securities will not be guaranteed by any of our other subsidiaries.

We are a holding company and conduct all of our operations through subsidiaries. Consequently, our ability to pay our obligations, including our obligation to pay interest on the debt securities, to repay the principal amount of the debt securities at maturity or upon redemption or to buy back the debt securities will depend upon our subsidiaries’ earnings and their distribution of those earnings to us and upon our subsidiaries repaying investments and advances we have made to them. Our subsidiaries are separate and distinct legal entities and, except for the cable guarantors with respect to the cable guarantees, have no obligation, contingent or otherwise, to pay any amounts due on the debt securities or to make funds available to us to do so. Our subsidiaries’ ability to pay dividends or make other payments or advances to us will depend upon their operating results and will be subject to applicable laws and contractual restrictions. Our indentures will not limit our subsidiaries’ ability to enter into other agreements that prohibit or restrict dividends or other payments or advances to us.

You should look in the applicable prospectus supplement for the following terms of the debt securities being offered:

- the designation of the debt securities;
- the aggregate principal amount of the debt securities;
- the percentage of their principal amount (*i.e.*, price) at which the debt securities will be issued;
- the date or dates on which the debt securities will mature and the right, if any, to extend such date or dates;
- the rate or rates, if any, per year, at which the debt securities will bear interest, or the method of determining such rate or rates;

Table of Contents

- the date or dates from which such interest will accrue, the interest payment dates on which such interest will be payable or the manner of determination of such interest payment dates and the record dates for the determination of holders to whom interest is payable on any interest payment dates;
- the right, if any, to extend the interest payment periods and the duration of that extension;
- provisions for a sinking fund purchase or other analogous fund, if any;
- the period or periods, if any, within which, the price or prices of which, and the terms and conditions upon which the debt securities may be redeemed, in whole or in part, at our option or at your option;
- the form of the debt securities;
- any provisions for payment of additional amounts for taxes and any provision for redemption, if we must pay such additional amounts in respect of any debt security;
- the terms and conditions, if any, upon which we may have to repay the debt securities early at your option and the price or prices in the currency or currency unit in which the debt securities are payable;
- the currency, currencies or currency units for which you may purchase the debt securities and the currency, currencies or currency units in which principal and interest, if any, on the debt securities may be payable;
- the terms and conditions, if any, pursuant to which the debt securities may be converted or exchanged for the cash value of other securities issued by us or by a third party;
- the right, if any, to “reopen” a series of the debt securities and issue additional debt securities of such series; and
- any other terms of the debt securities, including any additional events of default or covenants provided for with respect to the debt securities, and any terms which may be required by or advisable under applicable laws or regulations.

You may present debt securities for exchange and for transfer in the manner, at the places and subject to the restrictions set forth in the debt securities and the prospectus supplement. We will provide you those services without charge, although you may have to pay any tax or other governmental charge payable in connection with any exchange or transfer, as set forth in the indenture.

Debt securities will bear interest at a fixed rate or a floating rate. Debt securities bearing no interest or interest at a rate that at the time of issuance is below the prevailing market rate may be sold at a discount below their stated principal amount. Special United States federal income tax considerations applicable to any such discounted debt securities or to certain debt securities issued at par which are treated as having been issued at a discount for United States federal income tax purposes will be described in the relevant prospectus supplement.

We may issue debt securities with the principal amount payable on any principal payment date, or the amount of interest payable on any interest payment date, to be determined by reference to one or more currency exchange rates, securities or baskets of securities, commodity prices or indices. You may receive a payment of principal on any principal payment date, or a payment of interest on any interest payment date, that is greater than or less than the amount of principal or interest otherwise payable on such dates, depending upon the value on such dates of the applicable currency, security or basket of securities, commodity or index. Information as to the methods for determining the amount of principal or interest payable on any date, the currencies, securities or baskets of securities, commodities or indices to which the amount payable on such date is linked and certain additional tax considerations will be set forth in the applicable prospectus supplement.

Certain Terms of the Senior Debt Securities

Cable Guarantees

Our obligations under the senior debt securities, including the payment of principal, premium, if any, and interest, will be fully and unconditionally guaranteed by each of the cable guarantors. The cable guarantees will rank equally with all other general unsecured and unsubordinated obligations of the cable guarantors.

The cable guarantees will not contain any restrictions on the ability of any cable guarantor to:

- pay dividends or distributions on, or redeem, purchase, acquire, or make a liquidation payment with respect to, any of that cable guarantor's capital stock or
- make any payment of principal, interest or premium, if any, on or repay, repurchase or redeem any debt securities of that cable guarantor.

Certain Covenants

We and the cable guarantors have agreed to some restrictions on our activities for the benefit of holders of all series of senior debt securities issued under the senior indenture. The restrictive covenants summarized below will apply, unless the covenants are waived or amended, so long as any of the senior debt securities are outstanding.

The senior indenture does not contain any financial covenants other than those summarized below and does not restrict us or our subsidiaries from paying dividends or incurring additional debt. In addition, the senior indenture will not protect holders of notes issued under it in the event of a highly leveraged transaction or a change in control.

Limitation on Liens Securing Indebtedness. Neither we nor any cable guarantor shall create, incur or assume any Lien (other than any Permitted Lien) on such person's assets, including the Capital Stock of such person's wholly-owned subsidiaries, to secure the payment of our Indebtedness or that of any cable guarantor, unless we secure the outstanding senior debt securities equally and ratably with (or prior to) all Indebtedness secured by such Lien, so long as such Indebtedness shall be so secured.

Limitation on Sale and Leaseback Transactions. Neither we nor any cable guarantor shall enter into any Sale and Leaseback Transaction involving any of such person's assets, including the Capital Stock of such person's wholly-owned subsidiaries.

The restriction in the foregoing paragraph shall not apply to any Sale and Leaseback Transaction if:

- the lease is for a period not in excess of three years, including renewal of rights;
- the lease secures or relates to industrial revenue or similar financing;
- the transaction is solely between us and a cable guarantor or between or among cable guarantors; or
- we or the applicable cable guarantor, within 270 days after the sale is completed, applies an amount equal to or greater than (a) the net proceeds of the sale of the assets or part thereof leased or (b) the fair market value of the assets or part thereof leased (as determined in good faith by our Board of Directors) either to:
 - the retirement (or open market purchase) of senior debt securities, our other long-term Indebtedness ranking on a parity with or senior to the senior debt securities or long-term Indebtedness of a cable guarantor; or
 - the purchase by us or any cable guarantor of other property, plant or equipment related to our business or the business of any cable guarantor having a value at least equal to the value of the assets or part thereof leased.

This provision and the provision described under “—Limitation on Liens Securing Indebtedness” do not apply to any of our subsidiaries other than the cable guarantors.

Table of Contents

“Capitalized Lease” means, as applied to any person, any lease of any property (whether real, personal, or mixed) of which the discounted present value of the rental obligations of such person as lessee, in conformity with GAAP, is required to be capitalized on the balance sheet of such person; and **“Capitalized Lease Obligation”** is defined to mean the rental obligations, as aforesaid, under such lease.

“Capital Stock” means, with respect to any person, any and all shares, interests, participations, or other equivalents (however designated, whether voting or nonvoting) of such person’s capital stock or other ownership interests, whether outstanding as of, or issued after, the date of the senior indenture, including, without limitation, all common stock and preferred stock.

“Currency Agreement” means any foreign exchange contract, currency swap agreement, or other similar agreement or arrangement designed to protect against the fluctuation in currency values.

“GAAP” means generally accepted accounting principles in the United States of America as in effect as of the date of determination, including, without limitation, those set forth in the opinions and pronouncements of the Accounting Principles Board of the American Institute of Certified Public Accountants and statements and pronouncements of the Financial Accounting Standards Board or in such other statements by such other entity as approved by a significant segment of the accounting profession. All ratios and computations contained in the senior indenture shall be computed in conformity with GAAP applied on a consistent basis.

“Guarantee” means any obligation, contingent or otherwise, of any person directly or indirectly guaranteeing any Indebtedness or other obligation of any other person and, without limiting the generality of the foregoing, any obligation, direct or indirect, contingent or otherwise, of such person:

- to purchase or pay (or advance or supply funds for the purchase or payment of) such Indebtedness or other obligation of such other person (whether arising by virtue of partnership arrangements, or by agreement to keep-well, to purchase assets, goods, securities, or services, to take-or-pay, or to maintain financial statement conditions or otherwise); or
- entered into for purposes of assuring in any other manner the obligee of such Indebtedness or other obligation of the payment thereof or to protect such obligee against loss in respect thereof (in whole or in part);

provided that the term **“Guarantee”** shall not include endorsements for collection or deposit in the ordinary course of business. The term **“Guarantee”** used as a verb has a corresponding meaning.

“Indebtedness” means, with respect to any person at any date of determination (without duplication):

- all indebtedness of such person for borrowed money;
- all obligations of such person evidenced by bonds, debentures, notes, or other similar instruments;
- all obligations of such person in respect of letters of credit or other similar instruments (including reimbursement obligations with respect thereto);
- all obligations of such person to pay the deferred and unpaid purchase price of property or services (but excluding trade accounts payable or accrued liabilities arising in the ordinary course of business);
- all obligations of such person as lessee under Capitalized Leases;
- all Indebtedness of other persons secured by a Lien on any asset of such person, whether or not such Indebtedness is assumed by such person; provided that the amount of such Indebtedness shall be the lesser of:
 - the fair market value of such asset at such date of determination; and
 - the amount of such Indebtedness;
- all Indebtedness of other persons to the extent Guaranteed by such person;
- to the extent not otherwise included in this definition, obligations under Currency Agreements and Interest Rate Agreements.

Table of Contents

Notwithstanding the foregoing, in no event will the term “Indebtedness” be deemed to include letters of credit or bonds that secure performance or surety bonds or similar instruments that are issued in the ordinary course of business.

The amount of Indebtedness of any person at any date shall be the outstanding balance at such date of all unconditional obligations as described above and, with respect to contingent obligations, the maximum liability upon the occurrence of the contingency giving rise to the obligation; provided:

- that the amount outstanding at any time of any Indebtedness issued with original issue discount is the face amount of such Indebtedness less the remaining unamortized portion of the original issue discount of such Indebtedness at such time as determined in conformity with GAAP; and
- that Indebtedness shall not include any liability for federal, state, local, or other taxes.

“**Interest Rate Agreements**” means any obligations of any person pursuant to any interest rate swaps, caps, collars, and similar arrangements providing protection against fluctuations in interest rates. For purposes of the senior indenture, the amount of such obligations shall be the amount determined in respect thereof as of the end of the then most recently ended fiscal quarter of such person, based on the assumption that such obligation had terminated at the end of such fiscal quarter, and in making such determination, if any agreement relating to such obligation provides for the netting of amounts payable by and to such person thereunder or if any such agreement provides for the simultaneous payment of amounts by and to such person, then in each such case, the amount of such obligations shall be the net amount so determined, plus any premium due upon default by such person.

“**Lien**” means, with respect to any asset, any mortgage, lien, pledge, charge, security interest or encumbrance of any kind, or any other type of preferential arrangement that has the practical effect of creating a security interest, in respect of such asset. For the purposes of the senior indenture, we or any cable guarantor shall be deemed to own subject to a Lien any asset acquired or held subject to the interest of a vendor or lessor under any conditional sale agreement, capital lease or other title retention agreement relating to such asset.

“**Permitted Liens**” means:

- any Lien on any asset incurred prior to the date of the senior indenture;
- any Lien on any assets acquired after the date of the senior indenture (including by way of merger or consolidation) by us or any cable guarantor, which Lien is created, incurred or assumed contemporaneously with such acquisition, or within 270 days thereafter, to secure or provide for the payment or financing of any part of the purchase price thereof, or any Lien upon any assets acquired after the date of the senior indenture existing at the time of such acquisition (whether or not assumed by us or any cable guarantor), provided that any such Lien shall attach only to the assets so acquired;
- any Lien on any assets in favor of us or any cable guarantor;
- any Lien on assets incurred in connection with the issuance of tax-exempt governmental obligations (including, without limitation, industrial revenue bonds and similar financing);
- any Lien granted by any cable guarantor on assets to the extent limitations on the incurrence of such Liens are prohibited by any agreement to which such cable guarantor is subject as of the date of the senior indenture; and
- any renewal of or substitution for any Lien permitted by any of the preceding bullet points, including any Lien securing reborrowing of amounts previously secured within 270 days of the repayment thereof, provided that no such renewal or substitution shall extend to any assets other than the assets covered by the Lien being renewed or substituted.

“**Sale and Leaseback Transaction**” means any direct or indirect arrangement with any person or to which any such person is a party, providing for the leasing to us or a cable guarantor of any property, whether owned by us or such cable guarantor at the date of the original issuance of the debt securities or later acquired,

which has been or is to be sold or transferred by us or such cable guarantor to such person or to any other person by whom funds have been or are to be advanced on the security of such property.

Financial Information. We will file, whether or not required to do so under applicable law, with the trustee, within 15 days after being required to file the same under the Securities Exchange Act of 1934 (hereinafter, the “Exchange Act”), copies of the annual reports and the information, documents and other reports to be filed pursuant to Section 13 or 15(d) of the Exchange Act. We intend to file all such reports, information and documents with the SEC, whether or not required by Section 13 or 15(d), and will send copies to the trustee within such 15-day period.

Consolidation, Merger and Sale of Assets. The senior indenture restricts our ability to consolidate with, merge with or into, or sell, convey, transfer, lease, or otherwise dispose of all or substantially all of our property and assets to any person (other than a consolidation with or merger with or into or a sale, conveyance, transfer, lease or other disposition to a wholly-owned subsidiary with a positive net worth; provided that, in connection with any merger of us and a wholly-owned subsidiary, no consideration other than common stock in the surviving person shall be issued or distributed to our stockholders) unless:

- we are the continuing person or the person formed by such consolidation or into which we are merged or that acquired all or substantially all of our assets shall be a corporation or limited liability company organized and validly existing under the laws of the United States of America or any jurisdiction thereof and shall expressly assume, by a supplemental indenture, executed and delivered to the trustee, all of our obligations on all of the senior debt securities and under the senior indenture;
- immediately after giving effect to such transaction, no default or event of default shall have occurred and be continuing; and
- we deliver to the trustee an officers’ certificate and opinion of counsel, in each case stating that such consolidation, merger, or transfer and such supplemental indenture complies with this provision and that all conditions precedent provided for in the senior indenture and notes relating to such transaction have been complied with;

provided, however, that the foregoing limitations will not apply if, in the good faith determination of our board of directors set forth in a board resolution, the principal purpose of such transaction is to change our state of incorporation; and provided further that any such transaction shall not have as one of its purposes the evasion of the foregoing limitations.

Upon any express assumption of our obligations as described above, we will be released and discharged from all obligations and covenants under the senior indenture and all the senior debt securities.

The senior indenture and the cable guarantees do not limit the ability of any cable guarantor to consolidate with or merge into or sell all or substantially all its assets. Upon the sale or disposition of any cable guarantor (whether by merger, consolidation, the sale of its capital stock or the sale of all or substantially all of its assets) to any person, that cable guarantor will be deemed released from all its obligations under the senior indenture and its cable guarantee.

Events of Default

For purposes of this section, the term “Obligor” shall mean each of us, Comcast Cable, Comcast Cable Communications Holdings, Comcast Cable Holdings, Comcast MO Group and Comcast MO of Delaware, in each case excluding such entity’s subsidiaries.

An event of default for a series of senior debt securities is defined under the senior indenture as being:

(1) a default by any Obligor in the payment of principal or premium, if any, on the senior debt securities of such series when the same becomes due and payable, whether at maturity, upon redemption, by declaration or otherwise;

(2) a default by any Obligor in the payment of interest on the senior debt securities of such series when the same becomes due and payable, if that default continues for a period of 30 days;

Table of Contents

(3) default by any Obligor in the performance of or breach by any Obligor of any of its other covenants or agreements in the senior indenture applicable to the senior debt securities of such series and that default or breach continues for a period of 30 consecutive days after written notice is received from the trustee or from the holders of 25% or more in aggregate principal amount of the senior debt securities of all affected series;

(4) any cable guarantee is not (or is claimed by any cable guarantor not to be) in full force and effect;

(5) a court having jurisdiction enters a decree or order for:

- relief in respect of any Obligor in an involuntary case under any applicable bankruptcy, insolvency, or other similar law now or hereafter in effect;
- the appointment of a receiver, liquidator, assignee, custodian, trustee, sequestrator or similar official of any Obligor for any substantial part of such party's property and assets; or
- the winding up or liquidation of any Obligor's affairs and such decree or order shall remain unstayed and in effect for a period of 180 consecutive days; or

(6) any Obligor:

- commences a voluntary case under any applicable bankruptcy, insolvency, or other similar law now or hereafter in effect, or consents to the entry of an order for relief in an involuntary case under any such law;
- consents to the appointment of or taking possession by a receiver, liquidator, assignee, custodian, trustee, sequestrator, or similar official of such party or for any substantial part of such party's property; or
- effects any general assignment for the benefit of creditors.

A default under any Obligor's other indebtedness is not a default under the senior indenture.

If an event of default other than an event of default specified in clauses (5) and (6) above occurs with respect to an issue of senior debt securities and is continuing under the senior indenture, then, and in each and every such case, either the trustee or the holders of not less than 25% in aggregate principal amount of such senior debt securities then outstanding under the senior indenture by written notice to us (and to the trustee, if such notice is given by the holders), may declare the principal amount of and accrued interest, if any, on such senior debt securities to be immediately due and payable and upon any such declaration, the same shall become immediately due and payable. The amount due upon acceleration shall include only the original issue price of the senior debt securities and accrued interest to the date of acceleration, if any.

If an event of default specified in clauses (5) and (6) above occurs with respect to any Obligor, the principal amount of and accrued interest, if any, on each issue of senior debt securities then outstanding shall be and become immediately due and payable without any notice or other action on the part of the trustee or any holder. Upon certain conditions declarations of acceleration may be rescinded and annulled and past defaults may be waived by the holders of a majority in aggregate principal amount of an issue of senior debt securities that has been accelerated. Furthermore, subject to various provisions in the senior indenture, the holders of at least a majority in aggregate principal amount of an issue of senior debt securities by notice to the trustee may waive an existing default or event of default with respect to such senior debt securities and its consequences, except a default in the payment of principal of or interest on such senior debt securities or in respect of a covenant or provision of the senior indenture which cannot be modified or amended without the consent of the holders of each such senior debt security. Upon any such waiver, such default shall cease to exist, and any event of default with respect to such senior debt securities shall be deemed to have been cured, for every purpose of the senior indenture; but no such waiver shall extend to any subsequent or other default or event of default or impair any right consequent thereto. For information as to the waiver of defaults, see "—Modification and Waiver."

The holders of at least a majority in aggregate principal amount of an issue of senior debt securities may direct the time, method, and place of conducting any proceeding for any remedy available to the trustee or

exercising any trust or power conferred on the trustee with respect to such senior debt securities. However, the trustee may refuse to follow any direction that conflicts with law or the senior indenture, that may involve the trustee in personal liability, or that the trustee determines in good faith would be unduly prejudicial to the rights of holders of such issue of senior debt securities not joining in the giving of such direction and may take any other action it deems proper that is not inconsistent with any such direction received from holders of such issue of senior debt securities. A holder may not pursue any remedy with respect to the senior indenture or any series of senior debt securities unless:

- the holder gives the trustee written notice of a continuing event of default;
- the holders of at least 25% in aggregate principal amount of such series of senior debt securities make a written request to the trustee to pursue the remedy in respect of such event of default;
- the requesting holder or holders offer the trustee indemnity satisfactory to the trustee against any costs, liability, or expense; and
- the trustee does not comply with the request within 60 days after receipt of the request and the offer of indemnity.

These limitations, however, do not apply to the right of any holder of a senior debt security to receive payment of the principal of, premium, if any, or interest on such senior debt security, or to bring suit for the enforcement of any such payment, on or after the due date for the senior debt securities, which right shall not be impaired or affected without the consent of the holder. The senior indenture requires certain of our officers to certify, on or before a date not more than 120 days after the end of each fiscal year, as to their knowledge of our compliance with all conditions and covenants under the senior indenture, such compliance to be determined without regard to any period of grace or requirement of notice provided under the senior indenture.

Discharge and Defeasance

The senior indenture provides that, except as otherwise provided in this paragraph, we may discharge our obligations with respect to an issue of senior debt securities and the senior indenture with respect to that series of senior debt securities if:

- the senior debt securities of the affected series previously authenticated and delivered with certain exceptions, have been delivered to the trustee for cancellation and we have paid all sums payable under the senior indenture; or
- the senior debt securities of the affected series mature within one year or all of them are to be called for redemption within one year under arrangements satisfactory to the trustee for giving the notice of redemption and:
 - we irrevocably deposit in trust with the trustee, as trust funds solely for the benefit of the holders of the senior debt securities of the affected series, for that purpose, money or U.S. government obligations or a combination thereof sufficient (unless such funds consist solely of money, in the opinion of a nationally recognized firm of independent public accountants expressed in a written certification thereof delivered to the trustee), without consideration of any reinvestment and after payment of all federal, state and local taxes or other charges and assessments in respect thereof payable by the trustee, to pay principal of and interest on the senior debt securities of the affected series to maturity or redemption, as the case may be, and to pay all other sums payable by it under the senior indenture; and
 - we deliver to the trustee an officers' certificate and an opinion of counsel, in each case stating that all conditions precedent provided for in the senior indenture relating to the satisfaction and discharge of the senior indenture with respect to the senior debt securities of the affected series have been complied with.

With respect to all senior debt securities which have been delivered to the trustee for cancellation and for which have been paid all sums payable by us under the senior indenture, only our obligations

to compensate and indemnify the trustee and our right to recover excess money held by the trustee under the senior indenture shall survive. With respect to senior debt securities which mature within one year or are to be called for redemption within one year under redemption arrangements satisfactory to the trustee, only our obligations with respect to the issue of defeased senior debt securities, to execute and deliver such senior debt securities for authentication, to set the terms of such senior debt securities, to maintain an office or agency in respect of such senior debt securities, to have moneys held for payment in trust, to register the transfer or exchange of such senior debt securities, to deliver such senior debt securities for replacement or cancellation, to compensate and indemnify the trustee and to appoint a successor trustee, and our right to recover excess money held by the trustee shall survive until such senior debt securities are no longer outstanding. Thereafter, only our obligations to compensate and indemnify the trustee, and our right to recover excess money held by the trustee shall survive.

The senior indenture also provides that, except as otherwise provided in this paragraph, we:

- will be deemed to have paid and will be discharged from any and all obligations in respect of a series of senior debt securities, and the provisions of the senior indenture and the cable guarantees will no longer be in effect with respect to those senior debt securities (“legal defeasance”); and
- may omit to comply with any term, provision or condition of the senior indenture described above under “—Certain Covenants” and such omission shall be deemed not to be an event of default under the third clause of the first paragraph of “—Events of Default” with respect to that series of senior debt securities (“covenant defeasance”);

provided that the following conditions shall have been satisfied:

- we have irrevocably deposited in trust with the trustee as trust funds solely for the benefit of the holders of the senior debt securities of such series, for payment of the principal of and interest on the senior debt securities of such series, money or U.S. government obligations or a combination thereof sufficient (unless such funds consist solely of money, in the opinion of a nationally recognized form of independent public accountants expressed in a written certification thereof delivered to the trustee) without consideration of any reinvestment and after payment of all federal, state and local taxes or other charges and assessments in respect thereof payable by the trustee, to pay and discharge the principal of and accrued interest on the senior debt securities of such series to maturity or earlier redemption (irrevocably provided for under arrangements satisfactory to the trustee), as the case may be;
- such deposit will not result in a breach or violation of, or constitute a default under, the senior indenture, the cable guarantees or any other material agreement or instrument to which we are a party or by which we are bound;
- no default or event of default with respect to the senior debt securities of such series shall have occurred and be continuing on the date of such deposit;
- we shall have delivered to the trustee:
 - either an opinion of counsel that the holders of the senior debt securities of such series will not recognize income, gain or loss for federal income tax purposes as a result of our exercising our option under this provision of the senior indenture and will be subject to federal income tax on the same amount and in the same manner and at the same times as would have been the case if such deposit and defeasance had not occurred (which opinion, in the case of a legal defeasance, shall be based upon a change in law) or a ruling directed to the trustee received from the Internal Revenue Service to the same effect; and
 - an opinion of counsel that the holders of the senior debt securities of such series have a valid security interest in the trust funds subject to no prior liens under the Uniform Commercial Code; and

- we have delivered to the trustee an officers' certificate and an opinion of counsel, in each case stating that all conditions precedent provided for in the senior indenture relating to the defeasance contemplated of the senior debt securities of such series have been complied with.

Subsequent to legal defeasance under the first bullet point above, our obligations with respect to the issue of defeased senior debt securities to execute and deliver such senior debt securities for authentication, to set the terms of such senior debt securities, to maintain an office or agency in respect of such senior debt securities, to have moneys held for payment in trust, to register the transfer or exchange of such senior debt securities, to deliver such senior debt securities for replacement or cancellation, to compensate and indemnify the trustee and to appoint a successor trustee, and our right to recover excess money held by the trustee shall survive until such senior debt securities are no longer outstanding. After such senior debt securities are no longer outstanding, in the case of legal defeasance under the first bullet point above, only our obligations to compensate and indemnify the trustee and our right to recover excess money held by the trustee shall survive.

Modification and Waiver

We and the trustee may amend or supplement the senior indenture or the senior debt securities without notice to or the consent of any holder:

- to cure any ambiguity, defect, or inconsistency in the senior indenture; provided that such amendments or supplements shall not adversely affect the interests of the holders in any material respect;
- to comply with the provisions described under “—Certain Covenants—Consolidation, Merger and Sale of Assets;”
- to comply with any requirements of the SEC in connection with the qualification of the senior indenture under the Trust Indenture Act;
- to evidence and provide for the acceptance of appointment by a successor trustee;
- to establish the form or forms or terms of the senior debt securities as permitted by the senior indenture;
- to provide for uncertificated notes and to make all appropriate changes for such purpose;
- to make any change that does not adversely affect the rights of any holder;
- to add to its covenants such new covenants, restrictions, conditions or provisions for the protection of the holders, and to make the occurrence, or the occurrence and continuance, of a default in any such additional covenants, restrictions, conditions or provisions an event of default; or
- to make any change so long as no senior debt securities are outstanding.

Subject to certain conditions, without prior notice to any holder of senior debt securities, modifications and amendments of the senior indenture may be made by us and the trustee with respect to any series of senior debt securities with the written consent of the holders of a majority in principal amount of the affected series of senior debt securities, and our compliance with any provision of the senior indenture with respect to any series of senior debt securities may be waived by written notice to the trustee by the holders of a majority in principal amount of the affected series of senior debt securities outstanding; provided, however, that each affected holder must consent to any modification, amendment or waiver that:

- changes the stated maturity of the principal of, or any sinking fund obligation or any installment of interest on, the senior debt securities of the affected series;
- reduces the principal amount of, or premium, if any, or interest on, the senior debt securities of the affected series;
- changes the place or currency of payment of principal of, or premium, if any, or interest on, the senior debt securities of the affected series;

Table of Contents

- changes the provisions for calculating the optional redemption price, including the definitions relating thereto;
- changes the provisions relating to the waiver of past defaults or changes or impairs the right of holders to receive payment or to institute suit for the enforcement of any payment of the senior debt securities of the affected series on or after the due date therefor;
- reduces the above-stated percentage of outstanding senior debt securities of the affected series the consent of whose holders is necessary to modify or amend or to waive certain provisions of or defaults under the senior indenture;
- alters or impairs the right of holders to convert the senior debt securities of the affected series at the rate and upon the terms provided in the senior indenture;
- waives a default in the payment of principal of, premium, if any, or interest on the senior debt securities;
- adversely affects the rights of such holder under any mandatory redemption or repurchase provision or any right of redemption or repurchase that such holder has;
- modifies any of the provisions of this paragraph, except to increase any required percentage or to provide that certain other provisions cannot be modified or waived without the consent of the holder of each senior debt security of the series affected by the modification; or
- changes or waives any provision in the senior indenture that, pursuant to a board resolution or supplemental indenture establishing the terms of one or more series of senior debt securities, is prohibited from being so changed or waived.

It is not necessary for the consent of the holders under the senior indenture to approve the particular form of any note amendment, supplement or waiver, but it shall be sufficient if such consent approves the substance thereof. After an amendment, supplement or waiver under the senior indenture becomes effective, notice must be given to the holders affected thereby briefly describing the amendment, supplement, or waiver. Supplemental indentures will be mailed to holders upon request. Any failure to mail such notice, or any defect therein, shall not, however, in any way impair or affect the validity of any such supplemental indenture or waiver.

No Personal Liability of Incorporators, Stockholders, Officers, Directors, or Employees

The senior indenture provides that no recourse shall be had under or upon any obligation, covenant, or agreement of ours or the cable guarantors in the senior indenture or any supplemental indenture, or in any of the senior debt securities or because of the creation of any indebtedness represented thereby, against any incorporator, stockholder, officer, director, employee of ours or any cable guarantor or of any successor person thereof under any law, statute or constitutional provision or by the enforcement of any assessment or by any legal or equitable proceeding or otherwise. Each holder, by accepting the senior debt securities, waives and releases all such liability.

Concerning the Trustee

The senior indenture provides that, except during the continuance of a default, the trustee will not be liable, except for the performance of such duties as are specifically set forth in the senior indenture. If an event of default has occurred and is continuing, the trustee will exercise such rights and powers vested in it under the senior indenture and will use the same degree of care and skill in its exercise as a prudent person would exercise under the circumstances in the conduct of such person's own affairs.

Governing Law

The senior indenture and the debt securities will be governed by, and construed in accordance with, the internal laws of the State of New York.

The Trustees

We may have normal banking relationships with the trustee under the senior indenture in the ordinary course of business.

Brian L. Roberts, our director, President and Chief Executive Officer and a director of Comcast Holdings, is a member of the board of directors of the Trustee.

John R. Alchin, our Executive Vice President, Co-Chief Financial Officer and Treasurer, is a member of the board of directors of BNY Hamilton Funds, Inc., an affiliate of the Trustee.

Certain Terms of the Subordinated Debt Securities

Other than the terms of the subordinated indenture and subordinated debt securities relating to subordination, or otherwise as described in the prospectus supplement relating to a particular series of subordinated debt securities, the terms of the subordinated indenture and subordinated debt securities are identical in all material respects to the terms of the senior indenture and senior debt securities.

Subordination

The indebtedness evidenced by the subordinated debt securities is subordinate to the prior payment in full of all our Senior Indebtedness, as defined in the subordinated indenture. During the continuance beyond any applicable grace period of any default in the payment of principal, premium, interest or any other payment due on any of our Senior Indebtedness, we may not make any payment of principal of, or premium, if any, or interest on the subordinated debt securities. In addition, upon any payment or distribution of our assets upon any dissolution, winding up, liquidation or reorganization, the payment of the principal of, or premium, if any, and interest on the subordinated debt securities will be subordinated to the extent provided in the subordinated indenture in right of payment to the prior payment in full of all our Senior Indebtedness. Because of this subordination, if we dissolve or otherwise liquidate, holders of our subordinated debt securities may receive less, ratably, than holders of our Senior Indebtedness. The subordination provisions do not prevent the occurrence of an event of default under the subordinated indenture.

The subordination provisions also apply in the same way to each cable guarantor with respect to the Senior Indebtedness of such cable guarantor.

The term "Senior Indebtedness" of a person means with respect to such person the principal of, premium, if any, interest on, and any other payment due pursuant to any of the following, whether outstanding on the date of the subordinated indenture or incurred by that person in the future:

- all of the indebtedness of that person for money borrowed, including any indebtedness secured by a mortgage or other lien which is (1) given to secure all or part of the purchase price of property subject to the mortgage or lien, whether given to the vendor of that property or to another lender, or (2) existing on property at the time that person acquires it;
- all of the indebtedness of that person evidenced by notes, debentures, bonds or other securities sold by that person for money;
- all of the lease obligations which are capitalized on the books of that person in accordance with generally accepted accounting principles;
- all indebtedness of others of the kinds described in the first two bullet points above and all lease obligations of others of the kind described in the third bullet point above that the person, in any manner, assumes or guarantees or that the person in effect guarantees through an agreement to purchase, whether that agreement is contingent or otherwise; and
- all renewals, extensions or refundings of indebtedness of the kinds described in the first, second or fourth bullet point above and all renewals or extensions of leases of the kinds described in the third or fourth bullet point above;

unless, in the case of any particular indebtedness, lease, renewal, extension or refunding, the instrument or lease creating or evidencing it or the assumption or guarantee relating to it expressly provides that such

indebtedness, lease, renewal, extension or refunding is not superior in right of payment to the subordinated debt securities. Our senior debt securities, and any unsubordinated guarantee obligations of ours or any cable guarantor to which we and the cable guarantors are a party, including our and the cable guarantors', guarantees of each others' debt securities and other indebtedness for borrowed money, constitute Senior Indebtedness for purposes of the subordinated debt indenture.

Convertible Debt Securities

The terms, if any, on which debt securities being offered may be exchanged for or converted into other debt securities or shares of preferred stock, Class A Common Stock or Class A Special Common Stock or other securities or rights of ours (including rights to receive payments in cash or securities based on the value, rate or price of one or more specified commodities, currencies or indices) or securities of other issuers or any combination of the foregoing will be set forth in the prospectus supplement for such debt securities being offered.

Unless otherwise indicated in the prospectus supplement, the following provisions will apply to debt securities being offered that may be exchanged for or converted into capital stock:

The holder of any debt securities convertible into capital stock will have the right exercisable at any time during the time period specified in the prospectus supplement, unless previously redeemed by us, to convert such debt securities into shares of capital stock, which may include preferred stock, Class A Common Stock or Class A Special Common Stock, as specified in the prospectus supplement, at the conversion rate for each \$1,000 principal amount of debt securities set forth in the prospectus supplement, subject to adjustment.

The holder of a convertible debt security may convert a portion thereof which is \$1,000 or any integral multiple of \$1,000. In the case of debt securities called for redemption, conversion rights will expire at the close of business on the business day prior to the date fixed for the redemption as may be specified in the prospectus supplement, except that in the case of redemption at the option of the debt security holder, if applicable, such right will terminate upon receipt of written notice of the exercise of such option.

Unless the terms of the specific debt securities being offered provide otherwise, in certain events, the conversion rate will be subject to adjustment as set forth in the indentures. Such events include:

- the issuance of shares of any class of capital stock of ours as a dividend on the class of capital stock into which the debt securities of such series are convertible;
- subdivisions, combinations and reclassifications of the class of capital stock into which debt securities of such series are convertible;
- the issuance to all holders of the class of capital stock into which debt securities of such series are convertible or rights or warrants entitling the debt security holders (for a period not exceeding 45 days) to subscribe for or purchase shares of such class of capital stock at a price per share less than the current market price per share of such class of capital stock;
- the distribution to all holders of the class of capital stock into which debt securities of such series are convertible of evidences of indebtedness of ours or of assets or subscription rights or warrants (other than those referred to above); and
- distributions of cash in excess of certain threshold amounts.

In the case of cash dividends in excess of threshold amounts, we may, at our option, choose to set aside the amount of such distribution in cash for distribution to the holder upon conversion rather than adjust the conversion rate; we do not intend to pay interest on the cash set aside.

No adjustment of the conversion rate will be required unless an adjustment would require a cumulative increase or decrease of at least 1% in such rate. Fractional shares of capital stock will not be issued upon conversion but, in lieu thereof, we will pay a cash adjustment. Convertible debt securities surrendered for conversion between the record date for an interest payment, if any, and the interest payment date, except convertible debt securities called for redemption on a redemption date during such period, must be accompanied by payment of an amount equal to the interest thereon which the registered holder is to receive.

GLOBAL SECURITIES

We may issue the debt securities, warrants, purchase contracts and units of any series in the form of one or more fully registered global securities that will be deposited with a depository or with a nominee for a depository identified in the prospectus supplement relating to such series and registered in the name of the depository or its nominee. In that case, one or more global securities will be issued in a denomination or aggregate denominations equal to the portion of the aggregate principal or face amount of outstanding registered securities of the series to be represented by such global securities. Unless and until the depository exchanges a global security in whole for securities in definitive registered form, the global security may not be transferred except as a whole by the depository to a nominee of the depository or by a nominee of the depository to the depository or another nominee of the depository or by the depository or any of its nominees to a successor of the depository or a nominee of such successor.

The specific terms of the depository arrangement with respect to any portion of a series of securities to be represented by a global security will be described in the prospectus supplement relating to such series. We anticipate that the following provisions will apply to all depository arrangements.

Ownership of beneficial interests in a global security will be limited to persons that have accounts with the depository for such global security known as “participants” or persons that may hold interests through such participants. Upon the issuance of a global security, the depository for such global security will credit, on its book-entry registration and transfer system, the participants’ accounts with the respective principal or face amounts of the securities represented by such global security beneficially owned by such participants. The accounts to be credited shall be designated by any dealers, underwriters or agents participating in the distribution of such securities. Ownership of beneficial interests in such global security will be shown on, and the transfer of such ownership interests will be effected only through, records maintained by the depository for such global security (with respect to interests of participants) and on the records of participants (with respect to interests of persons holding through participants). The laws of some states may require that certain purchasers of securities take physical delivery of such securities in definitive form. Such limits and such laws may impair the ability to own, transfer or pledge beneficial interests in global securities.

So long as the depository for a global security, or its nominee, is the registered owner of such global security, such depository or such nominee, as the case may be, will be considered the sole owner or holder of the securities represented by such global security for all purposes under the applicable indenture, warrant agreement, purchase contract or unit agreement. Except as set forth below, owners of beneficial interests in a global security will not be entitled to have the securities represented by such global security registered in their names, will not receive or be entitled to receive physical delivery of such securities in definitive form and will not be considered the owners or holders thereof under the applicable indenture, warrant agreement, purchase contract or unit agreement. Accordingly, each person owning a beneficial interest in a global security must rely on the procedures of the depository for such global security and, if such person is not a participant, on the procedures of the participant through which such person owns its interest, to exercise any rights of a holder under the applicable indenture, warrant agreement, purchase contract or unit agreement. We understand that under existing industry practices, if we request any action of holders or if an owner of a beneficial interest in a global security desires to give or take any action which a holder is entitled to give or take under the applicable indenture, warrant agreement, purchase contract or unit agreement, the depository for such global security would authorize the participants holding the relevant beneficial interests to give or take such action, and such participants would authorize beneficial owners owning through such participants to give or take such action or would otherwise act upon the instructions of beneficial owners holding through them.

Principal, premium, if any, and interest payments on debt securities, and any payments to holders with respect to warrants, purchase contracts or units represented by a global security registered in the name of a depository or its nominee will be made to such depository or its nominee, as the case may be, as the registered owner of such global security. None of us, the trustees, the warrant agents, the unit agents or any of our other agents, agent of the trustees or agent of the warrant agents or unit agents will have any responsibility or liability for any aspect of the records relating to or payments made on account of beneficial ownership

interests in such global security or for maintaining, supervising or reviewing any records relating to such beneficial ownership interests.

We expect that the depositary for any securities represented by a global security, upon receipt of any payment of principal, premium, interest or other distribution of underlying securities or commodities to holders in respect of such global security, will immediately credit participants' accounts in amounts proportionate to their respective beneficial interests in such global security as shown on the records of such depositary. We also expect that payments by participants to owners of beneficial interests in such global security held through such participants will be governed by standing customer instructions and customary practices, as is now the case with the securities held for the accounts of customers in bearer form or registered in "street name," and will be the responsibility of such participants.

If the depositary for any securities represented by a global security is at any time unwilling or unable to continue as depositary or ceases to be a clearing agency registered under the Exchange Act, and we do not appoint a successor depositary registered as a clearing agency under the Exchange Act within 90 days, we will issue such securities in definitive form in exchange for such global security. In addition, we may at any time and in our sole discretion determine not to have any of the securities of a series represented by one or more global securities and, in such event, will issue securities of such series in definitive form in exchange for all of the global security or securities representing such securities. Any securities issued in definitive form in exchange for a global security will be registered in such name or names as the depositary shall instruct the relevant trustee, warrant agent or other relevant agent of ours. We expect that such instructions will be based upon directions received by the depositary from participants with respect to ownership of beneficial interests in such global security.

DESCRIPTION OF CAPITAL STOCK

The statements made under this caption include summaries of certain provisions contained in our articles of incorporation and by-laws. These statements do not purport to be complete and are qualified in their entirety by reference to such articles of incorporation and by-laws.

We have three classes of common stock outstanding: Class A Common Stock, \$0.01 par value per share; Class A Special Common Stock, \$0.01 par value per share; and Class B Common Stock, \$0.01 par value per share. There are currently authorized 7.5 billion shares of Class A Common Stock, 7.5 billion shares of Class A Special Common Stock and 75 million shares of Class B Common Stock.

Dividends

Subject to the preferential rights of any preferred stock then outstanding, Holders of our Class A Common Stock, Class A Special Common Stock, and Class B Common Stock are entitled to receive, from time to time, when, as and if declared, in the discretion of our Board, such cash dividends as our Board may from time to time determine, out of such funds as are legally available therefor, in proportion to the number of shares held by them, respectively, without regard to class.

Holders of our Class A Common Stock, Class A Special Common Stock, and Class B Common Stock will also be entitled to receive, from time to time, when, as and if declared by our Board, such dividends of our stock or other property as our Board may determine, out of such funds as are legally available therefor. However, stock dividends on, or stock splits of, any class of common stock will not be paid or issued unless paid or issued on all classes of our common stock, in which case they will be paid or issued only in shares of that class; provided, however, that stock dividends on, or stock splits of, our Class B Common Stock may also be paid or issued in shares of our Class A Special Common Stock.

We do not intend to pay dividends on our common stock for the foreseeable future.

Voting Rights

Except as required by law, holders of our Class A Special Common Stock are not entitled to vote. When holders of our Class A Special Common Stock are entitled to vote by applicable law, each share of our Class A Special Common Stock has the same number of votes as each share of our Class A Common Stock.

On all matters submitted for a vote of holders of all classes of our voting stock, holders of our Class A Common Stock in the aggregate hold $66\frac{2}{3}\%$ of the aggregate voting power of our capital stock as of February 28, 2006.

Each share of our Class A Common Stock has the number of votes equal to a quotient the numerator of which is the excess of (1) the Total Number of Votes (as defined below in this paragraph) over (2) the sum of (A) the Total Number of B Votes (as defined below in this paragraph) and (B) the Total Number of Other Votes (as defined below in this paragraph) and the denominator of which is the number of outstanding shares of our Class A Common Stock. "Total Number of Votes" on any record date is equal to a quotient the numerator of which is the Total Number of B Votes on such record date and the denominator of which is the B Voting Percentage (as defined below in this paragraph) on such record date. "Total Number of B Votes" on any record date is equal to the product of (1) 15 and (2) the number of outstanding shares of our Class B Common Stock on such record date. "Total Number of Other Votes" on any record date means the aggregate number of votes to which holders of all classes of our capital stock other than holders of our Class A Common Stock and our Class B Common Stock are entitled to cast on such record date in an election of directors. "B Voting Percentage" on any record date means the portion (expressed as a percentage) of the total number of votes to which all holders of our Class B Common Stock are entitled to cast on such record date in an election of directors. Initially, the B Voting Percentage will be $33\frac{1}{3}\%$, subject to reduction as described below.

Subject to the next sentence, on all matters submitted for a vote of holders of one or more classes of our voting stock, holders of our Class B Common Stock in the aggregate will hold $33\frac{1}{3}\%$ of the aggregate voting power of our capital stock, regardless of the number of shares of our Class A Common Stock or any other

class of our capital stock outstanding at any time. If the number of shares of our Class B Common Stock outstanding is reduced for any reason (*e.g.*, by repurchase or conversion), the aggregate voting power of our Class B Common Stock will be proportionately reduced.

Each share of our Class B Common Stock has 15 votes.

Approval Rights

Except as required by law, holders of Class A Special Common Stock and Class A Common Stock have no specific approval rights over any corporate actions. Holders of our Class B Common Stock have an approval right over (1) any merger of us with another company or any other transaction, in each case that requires our shareholders' approval under applicable law, or any other transaction that would result in any person or group owning shares representing in excess of 10% of the aggregate voting power of the resulting or surviving corporation, or any issuance of securities (other than pursuant to director or officer stock option or purchase plans) requiring our shareholders' approval under the rules and regulations of any stock exchange or quotation system; (2) any issuance of our Class B Common Stock or any securities exercisable or exchangeable for or convertible into our Class B Common Stock; and (3) charter or bylaw amendments (such as a charter amendment to opt in to any of the Pennsylvania antitakeover statutes) and other actions (such as the adoption, amendment or redemption of a shareholder rights plan) that limit the rights of holders of our Class B Common Stock or any subsequent transferee of our Class B Common Stock to transfer, vote or otherwise exercise rights with respect to our capital stock.

Principal Shareholder

Brian L. Roberts, our President and CEO, through his control of BRCC Holdings LLC and certain trusts, which own all outstanding shares of our Class B Common Stock, holds a nondilutable 33¹/₃% of the combined voting power of our stock and also has separate approval rights over certain material transactions involving us, as described above under "—Approval Rights." The Class B Common Stock is convertible on a share-for-share basis into Class A Common Stock or Class A Special Common Stock. As of February 28, 2006, if BRCC Holdings LLC, the trusts and Mr. Roberts were to convert the Class B Common Stock which they are deemed to beneficially own into Class A Common Stock, Mr. Roberts would beneficially own 10,170,995 shares of Class A Common Stock, which is less than 1% of the Class A Common Stock that would be outstanding after the conversion.

Conversion of Class B Common Stock

The Class B Common Stock is convertible share for share into either the Class A Common Stock or the Class A Special Common Stock.

Preference on Liquidation

In the event of our liquidation, dissolution or winding up, either voluntary or involuntary, the holders of Class A Special Common Stock, Class A Common Stock and Class B Common Stock are entitled to receive, subject to any liquidation preference of any preferred stock then outstanding, our remaining assets, if any, in proportion to the number of shares held by them without regard to class.

Mergers, Consolidations, Etc.

Our charter provides that if in a transaction such as a merger, consolidation, share exchange or recapitalization holders of each class of our common stock outstanding do not receive the same consideration for each of their shares of our common stock (*i.e.*, the same amount of cash or the same number of shares of each class of stock issued in the transaction in proportion to the number of shares of our common stock held by them, respectively, without regard to class), holders of each such class of our common stock will receive "mirror" securities (*i.e.*, shares of a class of stock having substantially equivalent rights as the applicable class of our common stock).

Miscellaneous

The holders of Class A Common Stock, Class A Special Common Stock and Class B Common Stock do not have any preemptive rights. All shares of Class A Common Stock, Class A Special Common Stock and Class B Common Stock presently outstanding are, and all shares of the Class A Common Stock and Class A Special Common Stock offered hereby, or issuable upon conversion, exchange or exercise of securities offered hereby, will, when issued, be, fully paid and non-assessable. We have been advised that the Class A Common Stock and Class A Special Common Stock are exempt from existing Pennsylvania personal property tax.

The transfer agent and registrar for our Class A Special Common Stock and Class A Common Stock is Computershare, 250 Royall Street, Canton, Massachusetts 02021. Their telephone number is (888) 883-8903.

Shareholder Rights Plan

The following description of the material terms of a rights agreement with respect to a shareholder rights plan is qualified by reference to the terms of the rights agreement, which is included as an exhibit to the registration statement of which this prospectus is a part.

The Rights. Pursuant to the rights agreement, our board declared on November 18, 2002 a dividend of one preferred stock purchase right (the “Rights”) for each outstanding share of our Class A Common Stock, Class A Special Common Stock and Class B Common Stock payable to holders of record on November 18, 2002. Shares of Common Stock issued after the record date and prior to the Distribution Date will be issued with a Right attached so that all shares of Common Stock outstanding prior to the Distribution Date will have Rights attached. 2.5 million shares of Preferred Stock have been reserved for issuance upon exercise of the Rights.

Rights holders have no rights as a shareholder of the Company, including the right to vote or to receive dividends.

The rights agreement includes antidilution provisions designed to prevent efforts to diminish the effectiveness of the Rights.

The transferability and exercisability of the Rights will depend on whether a “Distribution Date” has occurred. A Distribution Date generally means the earlier of (1) the close of business on the tenth day after a public announcement that any person or group has become an “Acquiring Person” and (2) the close of business on the tenth business day after the date of the commencement of a tender or exchange offer by any person that could result in such person becoming an Acquiring Person. An Acquiring Person generally means any person or group (other than any holder of our Class B common stock or any of such holder’s affiliates) who becomes the beneficial owner of our voting capital stock that represents 10% or more of the total number of votes that holders of our capital stock are entitled to cast with respect to any matter presented for a shareholder vote.

Transferability. Prior to the Distribution Date, (1) the Rights will be evidenced by the certificates of the relevant underlying common stock and the registered holders of the common stock shall be deemed the registered holders of the associated Rights and (2) the Rights will be transferable only in connection with transfers of shares of the underlying common stock. After the Distribution Date, the rights agent will mail separate certificates evidencing the Rights to each holder of the relevant underlying common stock as of the close of business on the Distribution Date. Thereafter, the Rights will be transferable separately from the common stock.

Exercisability. The Rights will not be exercisable prior to the Distribution Date. After the Distribution Date, but prior to the occurrence of an event described below under “—‘Flip In’ Feature” or “—‘Flip Over’ Feature,” each Right will be exercisable to purchase for \$125 one one-thousandth of a share of our Series A Participating Cumulative Preferred Stock.

“Flip In” Feature. If any person becomes an Acquiring Person, each holder of a Right, except for the Acquiring Person or certain affiliated persons, will have the right to acquire, instead of one one-thousandth of a share of our Series A Participating Cumulative Preferred Stock, a number of shares of our Class A common stock, in each case having a market value equal to twice the exercise price of the Right. For example, if an

initial purchase price of \$125 was in effect on the date that the flip in feature of the Rights was exercised, any holder of a Right, except for the person that has become an Acquiring Person or certain affiliated persons, could exercise his or her Right by paying to us \$125 in order to receive shares of our Class A common stock having a value equal to \$250.

“Exchange” Feature. At any time after a person becomes an Acquiring Person (but before any person becomes the beneficial owner of our voting capital stock representing 50% or more of the total number of votes which holders of our capital stock are entitled to cast with respect to any matter presented for a shareholder vote), our Board may exchange all or some of the Rights, except for those held by any Acquiring Person or certain affiliated persons, for our Class A common stock at an exchange ratio of one share of our Class A common stock for each Right. Use of this exchange feature means that eligible Rights holders would not have to pay cash before receiving shares of our Class A common stock.

“Flip Over” Feature. If, after a person becomes an Acquiring Person, (1) we are involved in a merger or other business combination in which we are not the surviving corporation or any of our common stock is exchanged for other securities or assets or (2) we and/or one or more of our subsidiaries sell or transfer assets or earning power aggregating 50% or more of the assets or earning power of us and/or our subsidiaries, then each Right will entitle the holder, except for any Acquiring Person or certain affiliated persons, to purchase a number of shares of common stock of the other party to the transaction having a value equal to twice the exercise price of the Right.

Redemption of Rights. Our Board may redeem all of the Rights at a price of \$0.001 per Right at any time prior to the time that any person becomes an Acquiring Person. The right to exercise will terminate upon redemption, and at that time, holders of the Rights will have the right to receive only the redemption price for each Right they hold.

Amendment of Rights. For so long as the Rights are redeemable, the rights agreement may be amended in any respect. At any time when the Rights are no longer redeemable, the rights agreement may be amended in any respect that does not adversely affect Rights holders (other than any Acquiring Person and certain affiliated persons), cause the rights agreement to become amendable except as set forth in this sentence or cause the Rights again to become redeemable.

Expiration of Rights. If not previously exercised or redeemed, the Rights will expire on November 18, 2012, unless earlier exchanged.

Anti-Takeover Effects. The Rights have certain anti-takeover effects. The Rights may cause substantial dilution to a person that attempts to acquire us without a condition to such an offer that a substantial number of the Rights be acquired or that the Rights be redeemed or declared invalid. The Rights should not interfere with any merger or other business combination approved by our Board since the Rights may be redeemed by us as described above.

Taxation. While the dividend of the Rights was not taxable to stockholders or to us, stockholders or we may, depending upon the circumstances, recognize taxable income in the event that the Rights become exercisable as set forth above.

Series A Preferred Stock. In connection with the creation of the Rights, our Board authorized the issuance of shares of our preferred stock designated as our Series A Participating Cumulative Preferred Stock. The dividend, liquidation, voting and redemption features of our Series A Participating Cumulative Preferred Stock have been designed so that the value of one-thousandth of a share of our Series A Participating Cumulative Preferred Stock approximates the value of one share of our Class A common stock. Shares of our Series A Participating Cumulative Preferred Stock will be purchasable only after the Rights have become exercisable. The rights of our Series A Participating Cumulative Preferred Stock as to dividends, liquidation and voting, and in the event of mergers or consolidations, are protected by customary antidilution provisions.

PLAN OF DISTRIBUTION

We may sell the securities being offered hereby in four ways:

- directly to purchasers;
- through agents;
- through underwriters; and
- through dealers.

We may directly solicit offers to purchase securities, or we may designate agents to solicit such offers. We will, in the prospectus supplement relating to such offering, name any agent that could be viewed as an underwriter under the Securities Act of 1933 (hereinafter, the “Securities Act”) and describe any commissions we or our trust subsidiaries must pay. Any such agent will be acting on a best efforts basis for the period of its appointment or, if indicated in the applicable prospectus supplement, on a firm commitment basis. Agents, dealers and underwriters may be customers of, engage in transactions with, or perform services for us in the ordinary course of business.

If any underwriters are utilized in the sale of the securities in respect of which this prospectus is delivered, we will enter into an underwriting agreement with them at the time of sale to them, and we will set forth in the prospectus supplement relating to such offering their names and the terms of our agreement with them.

If a dealer is utilized in the sale of the securities in respect of which the prospectus is delivered, we will sell such securities to the dealer, as principal. The dealer may then resell such securities to the public at varying prices to be determined by such dealer at the time of resale.

Remarketing firms, agents, underwriters and dealers may be entitled under agreements which they may enter into with us to indemnification by us against certain civil liabilities, including liabilities under the Securities Act, and may be customers of, engage in transactions with or perform services for us in the ordinary course of business.

In order to facilitate the offering of the securities, any underwriters may engage in transactions that stabilize, maintain or otherwise affect the price of the securities or any other securities the prices of which may be used to determine payments on such securities. Specifically, any underwriters may overallocate in connection with the offering, creating a short position for their own accounts. In addition, to cover overallocations or to stabilize the price of the securities or of any such other securities, the underwriters may bid for, and purchase, the securities or any such other securities in the open market. Finally, in any offering of the securities through a syndicate of underwriters, the underwriting syndicate may reclaim selling concessions allowed to an underwriter or a dealer for distributing the securities in the offering if the syndicate repurchases previously distributed securities in transactions to cover syndicate short positions, in stabilization transactions or otherwise. Any of these activities may stabilize or maintain the market price of the securities above independent market levels. Any such underwriters are not required to engage in these activities and may end any of these activities at any time.

Any underwriter, agent or dealer utilized in the initial offering of securities will not confirm sales to accounts over which it exercises discretionary authority without the prior specific written approval of its customer.

LEGAL MATTERS

As to matters governed by Pennsylvania law, Arthur R. Block, Esquire, Senior Vice President, General Counsel and Secretary of Comcast, and as to matters governed by New York and Delaware law, Davis Polk & Wardwell, will pass upon the validity of the securities on our behalf and on behalf of the cable guarantors, although we may use other counsel, including our employees, to do so. Unless otherwise indicated in the accompanying prospectus supplement, Cahill Gordon & Reindel will represent the underwriters.

EXPERTS

The financial statements, the related financial statement schedule, and management's report on the effectiveness of internal control over financial reporting, incorporated in this prospectus by reference from Comcast Corporation's Annual Report on Form 10-K, have been audited by Deloitte & Touche LLP, an independent registered public accounting firm, as stated in their reports, which are incorporated herein by reference, and have been so incorporated in reliance upon the reports of such firm given upon their authority as experts in accounting and auditing.

AVAILABLE INFORMATION

We, along with the cable guarantors, have filed this prospectus as part of a combined registration statement on Form S-3 with the SEC. The registration statement contains exhibits and other information that are not contained in this prospectus. In particular, the registration statement includes as exhibits forms of our underwriting agreements, copies of our senior indenture and subordinated indenture, forms of our senior debt security and subordinated debt security, a form of preferred security, a form of unit agreement, a form of purchase contract agreement, a form of pledge agreement, a form of warrant agreement for warrants sold separately, a form of warrant for warrants sold separately, a form of warrant agreement for warrants sold attached to securities, a form of warrant for warrants sold attached to securities, a form of deposit agreement and a form of depositary share. Our descriptions in this prospectus of the provisions of documents filed as exhibits to the registration statement or otherwise filed with the SEC are only summaries of the documents' material terms. If you want a complete description of the content of the documents, you should obtain the documents by following the procedures described below.

We file annual, quarterly and special reports and other information with the SEC. Comcast Cable Communications Holdings, Comcast Cable, Comcast Cable Holdings, Comcast MO Group and Comcast MO of Delaware do not currently file information with the SEC. Although the cable guarantors would normally be required to file information with the SEC on an ongoing basis, we expect that the cable guarantors will be exempt from this filing obligation for as long as we continue to file our information with the SEC. You may read and copy any document we file at the SEC's public reference room located at 100 F Street, NE, Washington, D.C. 20549. Please call the SEC at 1-800-SEC-0330 for further information on the public reference rooms. Our SEC filings, including the complete registration statement and all of the exhibits to it are available through the SEC's web site at <http://www.sec.gov>.

You should rely only on the information contained in this prospectus, in the accompanying prospectus supplement and in material we file with the SEC and incorporate by reference herein. We have not authorized anyone to provide you with information that is different. We are offering to sell, and seeking offers to buy, the securities described in the prospectus only where offers and sales are permitted. The information contained in this prospectus, the prospectus supplement and our filings with the SEC is accurate only as of its date, regardless of the time of delivery of this prospectus and the prospectus supplement or of any sale of the securities.

INCORPORATION OF CERTAIN DOCUMENTS BY REFERENCE

The SEC allows us to “incorporate by reference” the information we file with them, which means that we can disclose important information to you by referring you directly to those documents. The information incorporated by reference is considered to be part of this prospectus. In addition, information we file with the SEC in the future will automatically update and supersede information contained in this prospectus and any accompanying prospectus supplement.

This prospectus incorporates by reference the documents set forth below that we have previously filed with the SEC:

- Annual Report on Form 10-K for the year ended December 31, 2005, filed on February 22, 2006.
- The section of the Definitive Proxy Statement on Schedule 14A for the 2006 annual meeting of stockholders incorporated by reference in the Annual Report on Form 10-K for the year ended December 31, 2005.
- Current Reports on Form 8-K filed on January 26, 2006, February 28, 2006 and March 6, 2006.
- The description of our capital stock incorporated in our Current Report on Form 8-K12G3 and Registration Statement on Form 8-A12G, each filed on November 18, 2002, as the same may be amended from time to time.

We also incorporate by reference into this prospectus additional documents that we may file with the SEC under Sections 13(a), 13(c), 14 or 15(d) of the Exchange Act until we sell all of the securities we are offering. Any statements contained in a previously filed document incorporated by reference into this prospectus is deemed to be modified or superseded for purposes of this prospectus to the extent that a statement contained in this prospectus, or in a subsequently filed document also incorporated by reference herein, modifies or supersedes that statement. We will provide free copies of any of those documents, if you write or telephone us at: 1500 Market Street, Philadelphia, Pennsylvania 19102-2148, (215) 665-1700.



\$ % Notes due 2056

PROSPECTUS SUPPLEMENT

Joint Book-Running Managers

Citi

Merrill Lynch & Co.

Morgan Stanley

UBS Investment Bank

Wachovia Securities

A.G. Edwards

RBC Capital Markets

**Banc of America Securities LLC
JPMorgan**

**Deutsche Bank Securities
Lehman Brothers**

May , 2007
